

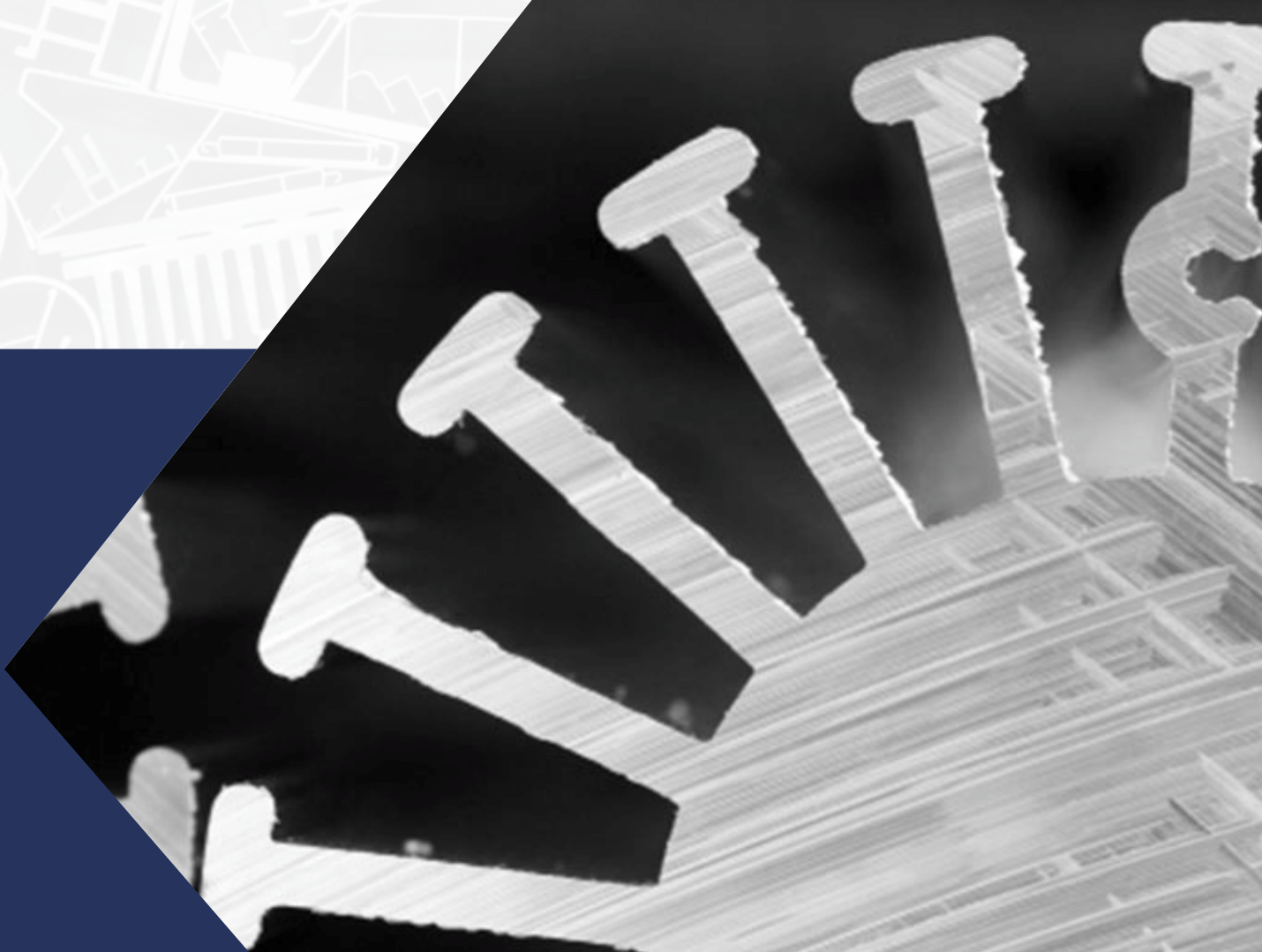

DISALPI
PERFIS E COMPONENTES



CATÁLOGO DE PERFIS

2020



2020

Av. Campos Sales, 795
Centro/Norte Teresina-PI
86 3304 4473 | 3304 4474
vendas@disalpialuminio.com.br
www.disalpialuminio.com.br

Atualizado 27.11.2019

Perfis	Página
Tabelados	6
Machos E Conexões	12
Contra Marcos E Arremates	13
Linha 25	14
Módulo Prático	17
Módulo Max	21
Venezianas	23
Unnion	24
Nova	28
Gold	30
Box Pesado	38
Box Leve	39
Temperado	40
Cortina de Vidro	50
Guarda Corpo/Corrimão	51
Vitrine	53
Portão	54
Pele de Vidro	60
Fachada Cortina	64
Diversos	65
Móveis	67

CÓDIGO	PÁGINA
25 001	14
25 002	14
25 011	14
25 016	14
25 021	16
25 026	14
25 027	14
25 301	21
25 308	21
25 311	21
25 312	21
25 504	15
25 508	15
25 517	15
25 518	58
25 538	16
25 540	15
25 542	15
25 548	15
25 549	66
25 551	66
28 515	23
AL 01	43
AL 02	43
AL 05	43
AL 06	45
AL 09	45
AL 10	44
AL 11	44
AL 13	43
AL 14	44
AL 15	42
AL 16	42
AL 17	44
AL 22	44
AL 26	47
AL 27	47
AL 300	45
AL 37	47
AL 44	48
AL 46	41
AL 47	42
AL 49	41
AL 50	41
AL 500	45

CÓDIGO	PÁGINA
AL 51	43
AL 52	43
AL 62	44
AL 63	41
AL 64	42
AL 65	41
AL 68	47
AL 75	41
AL 80	46
AL 81	46
AL 82	46
AL 83	46
AL 86	42
AL 87	42
AL 88	47
AL 89	47
AL 90	48
AL 91	48
AL 92	48
AL 93	48
AL 94	48
AL 95	48
AL 96	48
BG 001	16
BG 035	22
BG 035B	22
BG 202	20
BG 202B	20
BK 023	53
BK 024	53
BK 026	53
BX 106	38
BX 112	39
BX 159	38
BX 168	39
BX 169	39
BX 170	39
BX 171	39
BX 172	39
BX 174	38
BX 175	38
BX 185	38
BX 188	38
CA 002	13
CG 003	51

CÓDIGO	PÁGINA
CG 013	51
CG 074	51
CG 075	51
CG 077	51
CG 083	51
CG 171	52
CG 204	52
CG 213	52
CG 219	52
CL 006	12
CL 010	12
CL 011	12
CL 044	12
CM 063	13
CT 005B	13
CT 007B	13
CT 015B	13
CV 025	50
CV 026	50
CV 027	50
CV 028	50
CV 083	50
CV 084	50
D 0094	51
DC 026	65
DIN 015	29
DIN 017	28
DIN 018	28
DIN 054	28
DIN 055	28
DIN 056	28
DIN 058	28
DIN 061	28
DIN 065	29
DIN 066	29
DP 001	69
DP 010	67
DP 011T	68
DP 013	69
DP 014	69
DP 015	69
DP 020	69
DP 021	70
DP 022	70
DP 0227	70

CÓDIGO	PÁGINA
DP 026T	68
DP 030	69
DP 031	69
DP 035	68
DP 038	69
DP 039	69
DP 046	70
DP 047	70
DP 047L	70
DP 047M	70
DP 051	67
DP 053	67
DP 062	68
DP 076	67
DP 080	70
DP 091	68
DP 1036	67
DP 1145	67
DP 158	68
DP 201	68
DP 2016	70
DP 2163	67
DP 6073	68
DP 7041	68
DP 997	67
DPR 003	31
DPR 007	36
DS 023	57
DS 044	13
DS 164	65
DS 205	65
DS 264	65
DSP 049	40
DSP 050	40
DSP 051	40
DSP 052	40
DSP 252	40
DSP 253	40
DV 111	65
E 0077	56
ECO 701	24
ECO 703	26
ECO 705	26
ECO 706	27
ECO 707	27

CÓDIGO	PÁGINA
ECO 709	25
ECO 710	24
ECO 711	24
ECO 716	27
ECO 717	25
ECO 718	25
ECO 719	25
ECO 725	26
ECO 729	24
ECO 733	27
ECO 734	26
ECO 735	26
ECO 736	26
ECO 737	25
ECO 738	25
ECO 741	24
ECO 797	24
FC 012	64
FC 013	64
FC 014	64
FC 070	16
FC 085	61
FC 087	63
FC 088	63
FC 202	60
FC 222	60
FC 225	60
FC 226	61
FC 227	61
FC 231	62
FC 232	63
FC 242	62
FC 243	60
FC 244	62
FC 245	63
FC 249	61
FC 261	61
FC 293	60
FC 687	62
FC228	61
LB 010	54
LB 030	55
LB 036	54
LB 040	56
LB 050	54

CÓDIGO	PÁGINA
LB 070	56
LB 600	55
LB 602	55
LG 006	33
LG 002	32
LG 003	32
LG 004	36
LG 005	36
LG 007	33
LG 016	35
LG 017	34
LG 020	34
LG 021	34
LG 026	32
LG 028	32
LG 042	35
LG 043	35
LG 044	30
LG 047	30
LG 048	33
LG 049	33
LG 050	33
LG 051	34
LG 055	33
LG 056	35
LG 057	32
LG 058	37
LG 062	30
LG 066	30
LG 068	37
LG 070	30
LG 072	31
LG 074	37
LG 083	37
LG 085	37
LG 091	37
LG 111	31
LG 116	31
LG 117	36
LG 137	34
LG 140	34
LG 158	32
LG 159	31
LG 160	31
ME 013	12

CÓDIGO	PÁGINA
ME 029	12
ME 056	22
MM 375	21
MM 376	21
MP 069	18
MP 070	18
MP 300	17
MP 302	17
MP 309	17
MP 321	17
MP 332	18
MP 336	18
MP 337	18
MP 347	12
MP 352	19
MP 354	20
MP 357	19
MP 358	19
MP 359	19
MP 360	19
MP 363	18
MP 370	19
MP 372	17
MP 374	17
MP361	20
N 0009	53
N 0012	53
N 0042	53
N 0042	68
N 2311	13
N 2312	12
PC 002	59
PC 003	59
PC 027	58
PC 028	58
PC 029	58
PT 008	57
PU 639	57
TG 004	59
TG 004B	59
TG 005	49
TG 019	49
TG 038	49
TG 043	59
TG 073	59

CÓDIGO	PÁGINA
TPS 039	52
TQ 017	49
U 1098	66
US 280	23
VT 302	27
VZ 024	23
VZ 047	23
VZ 060	23

Perfil U Abas Iguais

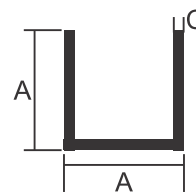

REFERÊNCIA	MILÍMETROS			POLEGADAS	
	A	B	C	A	B
PU 800	9,52	9,52	1,00	3/8	3/8
PU 002	12,7	12,7	1,4	1/2	1/2
PU 004	15,87	15,87	1,2	5/8	5/8
PU 008	19,05	19,05	1,58	3/4	3/4
PU 015	25,4	25,4	3,18	1	1

Perfil U Abas Desiguais

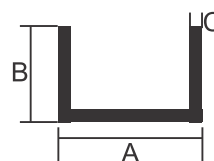

REFERÊNCIA	MILÍMETROS			POLEGADAS	
	A	B	C	A	B
AL 29	9,52	12,7	1,00	3/8	1/2
PU 639	29,0	35,0	1,2	-	-
AL 86	11,0	22,0	-	-	-
AL 87	14,0	22,0	-	-	-
AL 10	15,0	25,0	-	-	-

Barra Chata



REFERÊNCIA	MILÍMETROS		POLEGADAS	
	A	C	A	C
BC 002	9,52	3,18	1/2	1/8
BC 013	15,87	3,18	5/8	1/8
BC 014	15,87	4,76	5/8	3/16
BC 015	19,05	3,18	3/4	1/8
BC 016	19,05	4,76	3/4	3/16
BC 017	19,05	6,35	3/4	1/4
BC 025	25,4	3,18	1	1/8
BC 026	25,4	4,76	1	3/16
BC 027	25,4	6,35	1	1/4
BC 019	31,75	3,18	1.1/4	1/8
BC 093	31,75	6,35	1.1/4	1/4
BC 050	38,1	3,18	1.1/2	1/8
BC 060	50,8	3,18	2	1/8
BC 061	50,8	4,76	2	3/16

Barra Chata Cantos Arredondados



REFERÊNCIA	MILÍMETROS		POLEGADAS	
	A	C	A	C
PBA 006	15,87	4,76	5/8	3/16
PBA 032	19,05	4,76	3/4	3/16
PBA 050	25,4	6,35	1	1/4

Cantoneira Abas Iguais

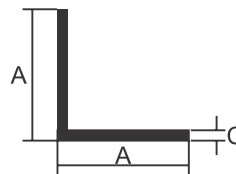

REFERÊNCIA	MILÍMETROS			POLEGADAS	
	A	B	C	A	C
CT 001	9,52	9,52	1,20	1/2	-
CT 005	15,87	15,87	1,20	5/8	-
CT 007	19,05	19,05	1,20	3/4	-
CT 015	25,40	25,40	1,20	1	-
CT 019	25,40	25,40	3,18	1	1/8
CT 022	31,75	31,75	3,18	1.1/4	1/8
CT 023	31,75	31,75	4,76	1.1/4	3/16
CT 047	38,1	38,1	1,58	1.1/2	1/16
CT 026	38,1	38,1	3,18	1.1/2	1/8
CT 027	38,1	38,1	4,76	1.1/2	3/16
CT 032	50,8	50,8	3,18	2	1/8
CT 033	50,8	50,8	4,76	2	3/16

Cantoneira Abas Desiguais

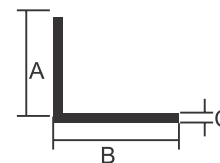

REFERÊNCIA	MILÍMETROS			POLEGADAS		
	A	B	C	A	B	C
CT 204	25,4	12,7	1,50	1	1/2	-
CT 209	31,75	19,05	3,18	1.1/4	3/4	1/8
CT 218	50,8	31,75	2,00	2	1.1/4	-

Perfil T

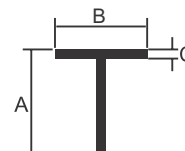

REFERÊNCIA	MILÍMETROS			POLEGADAS		
	A	B	C	A	B	C
PT 004	19,05	19,05	1,58	3/4	3/4	0
PT 008	25,4	25,4	1,20	1	1	-
PT 009	25,4	25,4	1,58	1	1,00	1/16

Tubo Quadrado

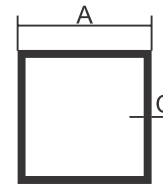

REFERÊNCIA	MILÍMETROS		POLEGADAS	
	A	C	A	C
TQ 004	19,05	1,00	3/4	-
TQ 006	19,05	1,58	3/4	1/16
TQ 023	25,4	1,00	1	-
TQ 009	25,4	1,58	1	1/16
TQ 012	31,75	1,58	1.1/4	1/16
TQ 013	38,1	1,20	1.1/2	-
TQ 014	38,1	1,58	1.1/2	1/16
TQ 017	50,8	1,58	2	1/16
TQ 060	101,6	1,8	4	-

Tubo Retangular

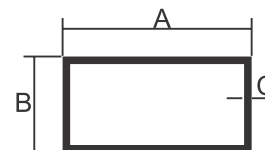

REFERÊNCIA	MILÍMETROS			POLEGADAS		
	A	B	C	A	B	C
TG 043	25,4	12,7	1,00	1	1/2	-
TG 004	50,8	12,7	1,00	2	1/2	-
TG 073	50,8	25,4	1,00	2	1	-
TG 005	50,8	25,4	1,58	2	1	1/16
TG 038	76,2	38,1	1,58	3	1.1/2	1/16
TG 019	101,6	50,8	1,78	4	2	-

Tubo Redondo

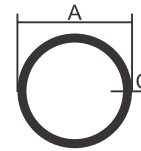

REFERÊNCIA	MILÍMETROS		POLEGADAS	
	A	C	A	C
TR 102	9,52	1,00	3/8	-
TR 002	9,52	1,58	3/8	1/16
TR 004	12,7	1,24	1/2	-
TR 005	12,7	1,58	1/2	1/16
TR 012	15,87	1,20	5/8	-
TR 019	19,05	1,20	3/4	-
TR 020	19,05	1,58	3/4	1/16
TR 032	22,22	1,00	7/8	-
TR 035	22,22	1,58	7/8	1/16
TR 039	25,4	1,00	1	-
TR 040	25,4	1,58	1	1/16
TR 055	31,75	1,58	1,1/4	1/16
TR 070	38,1	1,58	1,1/2	1/16
TR 098	50,8	1,58	2	1/16
TR 160	101,6	1,50	4	-
TR 160	101,6	2,00	4	-

Vergalhão Quadrado



REFERÊNCIA	MILÍMETROS	POLEGADAS
	A	A
VQ 001	6,35	1/4
VQ 003	9,52	3/8
VQ 005	12,70	1/2
VQ 009	19,05	3/4
VQ 008	25,4	3/4

Vergalhão Redondo

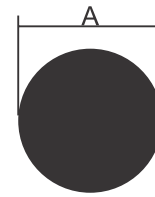

	MILÍMETROS	POLEGADAS
REFERÊNCIA	A	A
VR 002	6,23	1/4
VR 005	9,52	3/8
VR 010	12,70	1/2
VR 016	19,05	3/4
VR 020	25,4	1
VR 029	50,8	2

CL 006

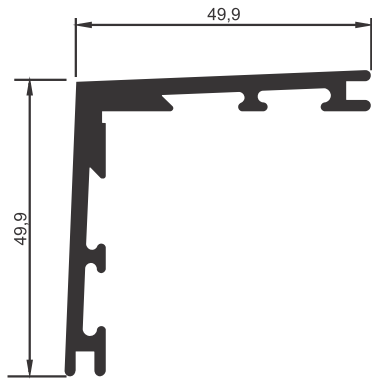

CL 044

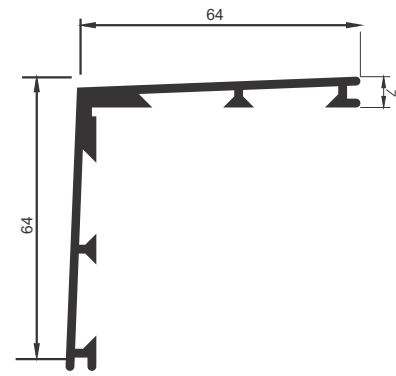

CL 011

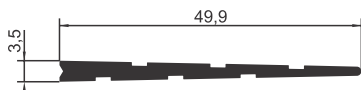

CL 010

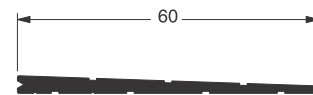

ME 029

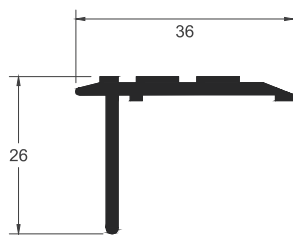

ME 013

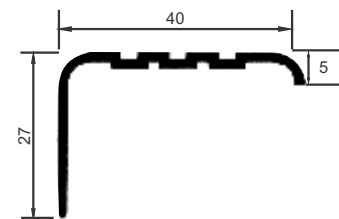

MP 347

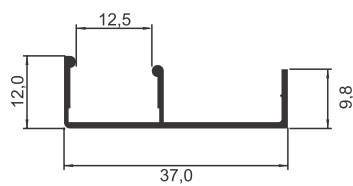

N 2312

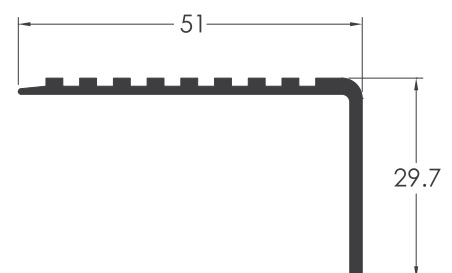

DS 044

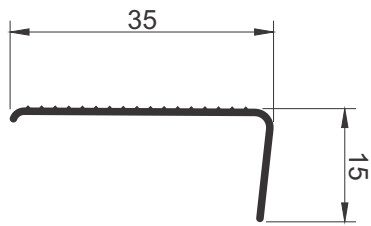

N 2311

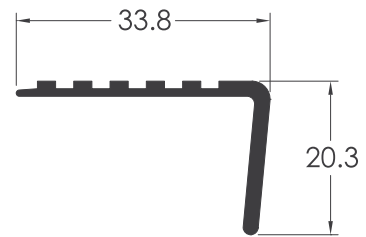

CM 063

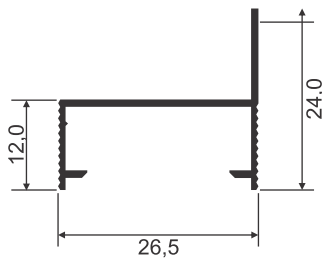

CT 015B

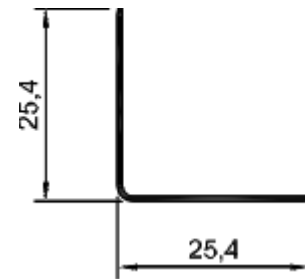

CT 005B

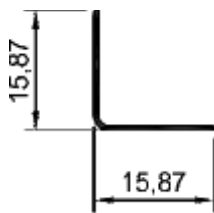

CT 007B

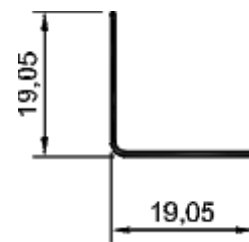

CA 002

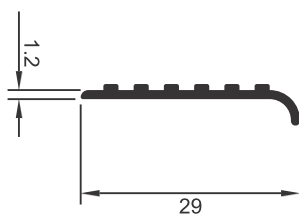

25 027

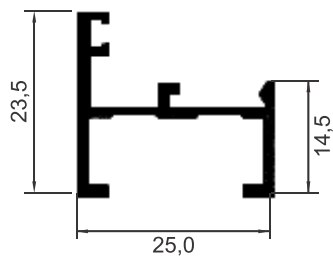

25 001

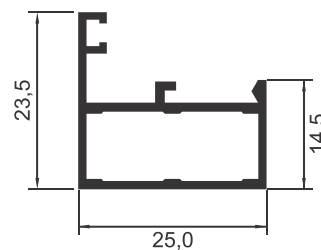

25 016

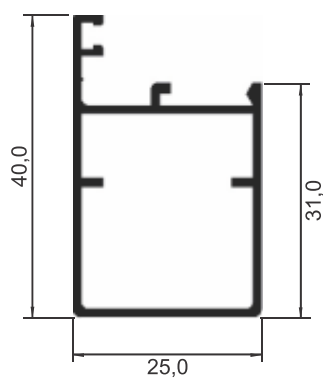

25 026

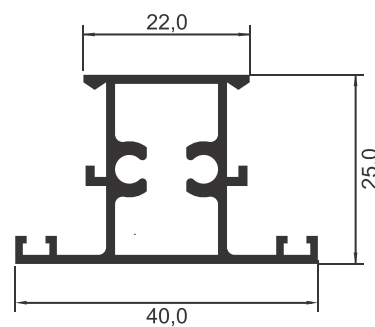
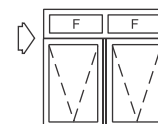

25 011

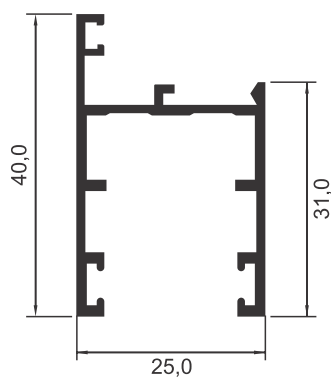
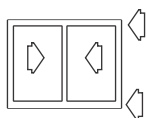

25 002

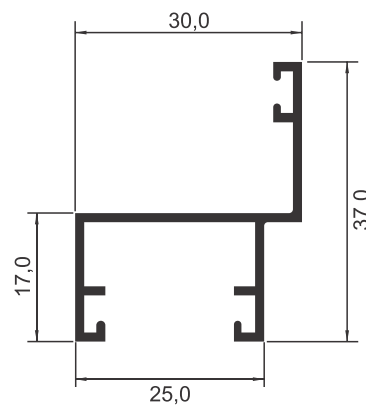
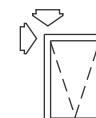

25 540

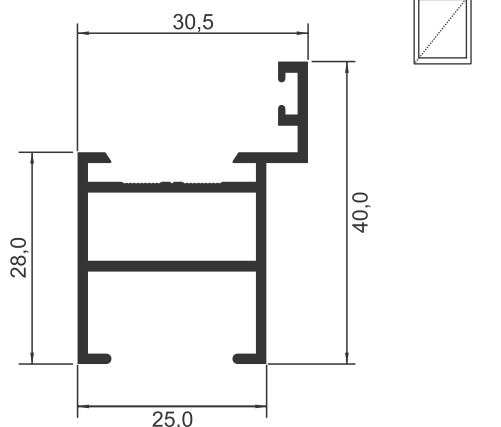

25 548

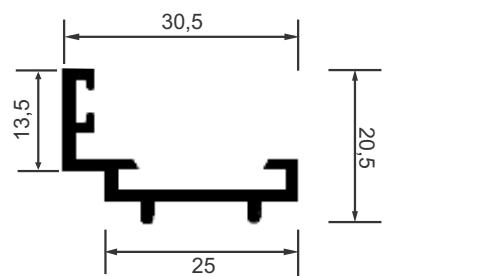

25 504

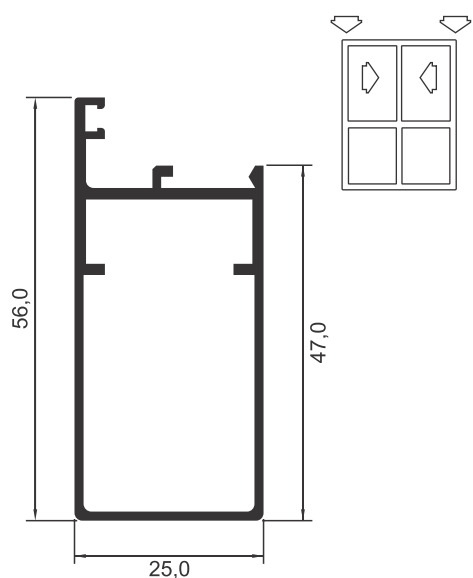

25 508

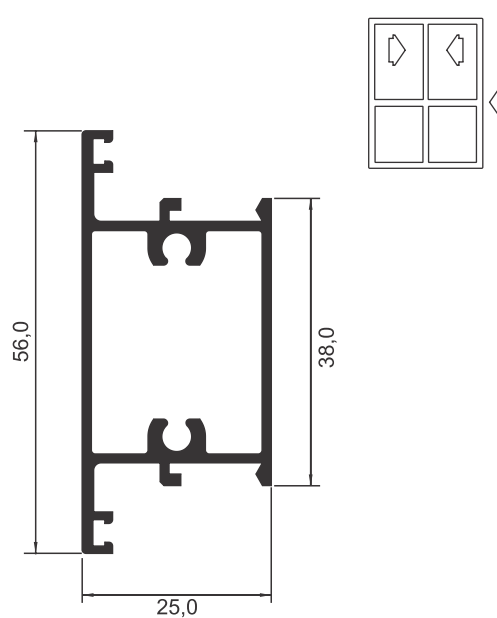

25 517

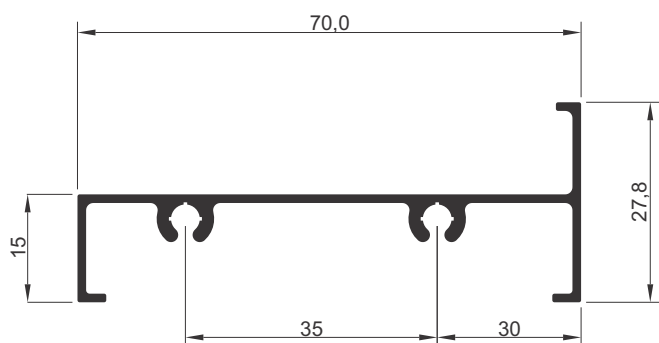

25 542

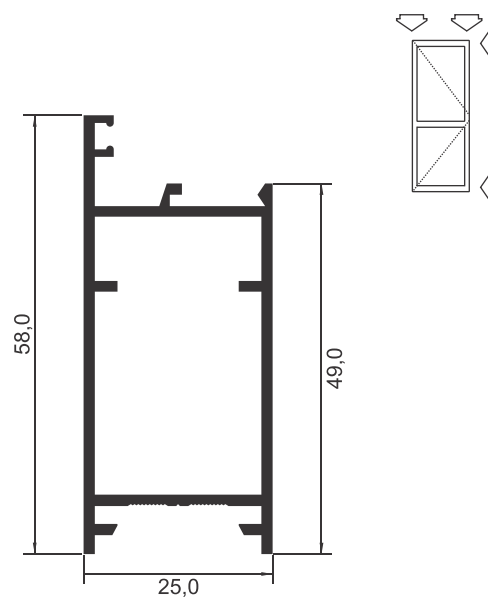

25 021

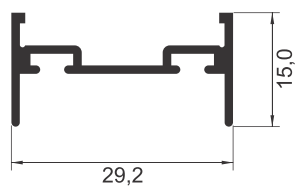

BG 001

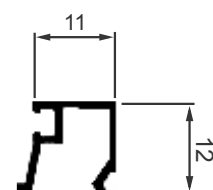

FC 070

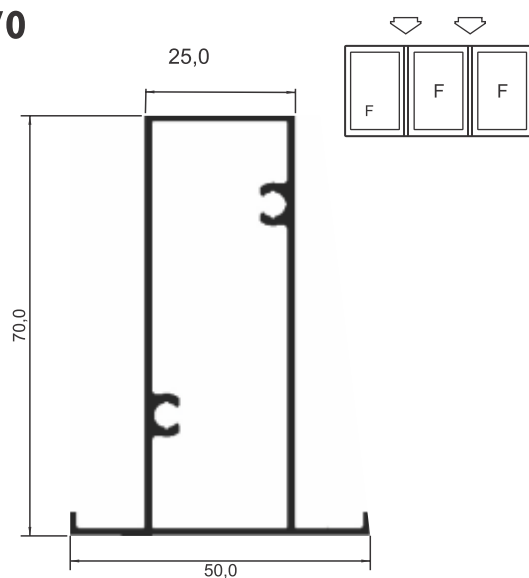

25 538

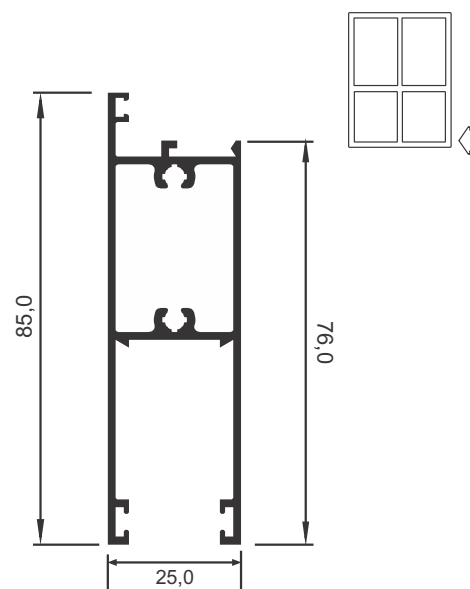

MP 300

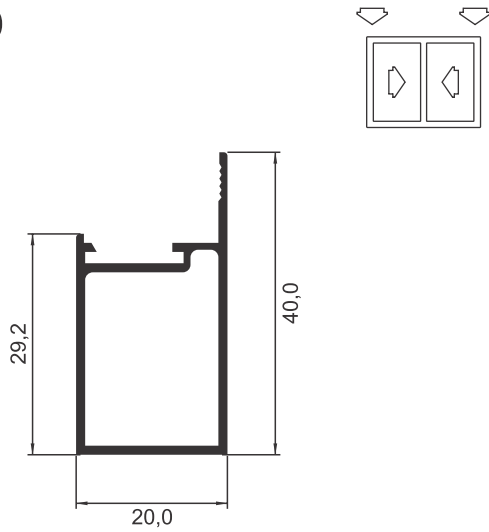

MP 302

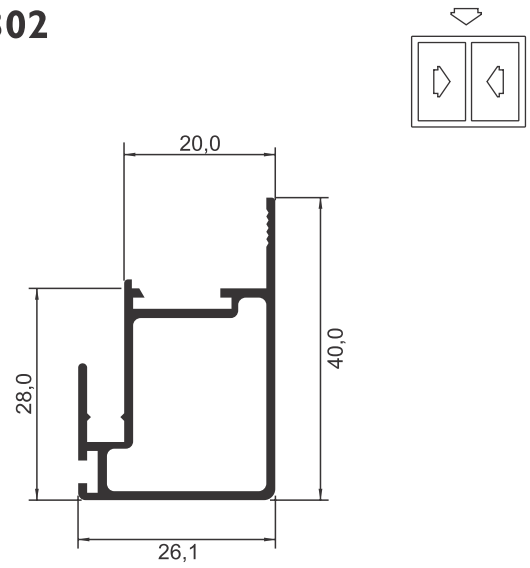

MP 309

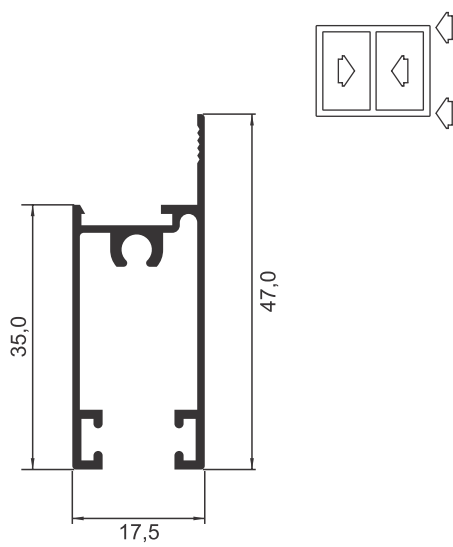

MP 321

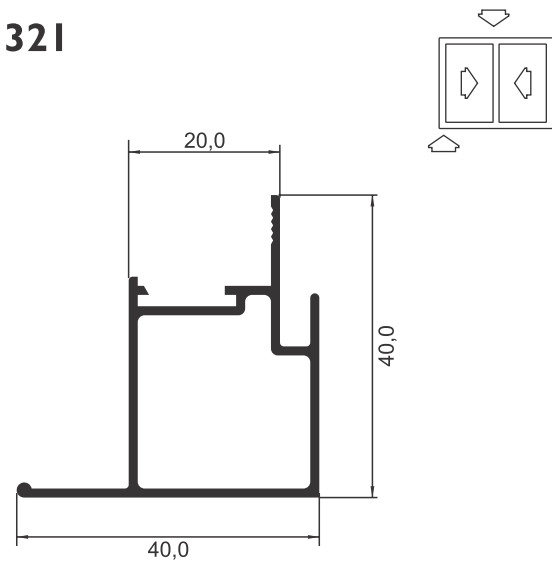

MP 372

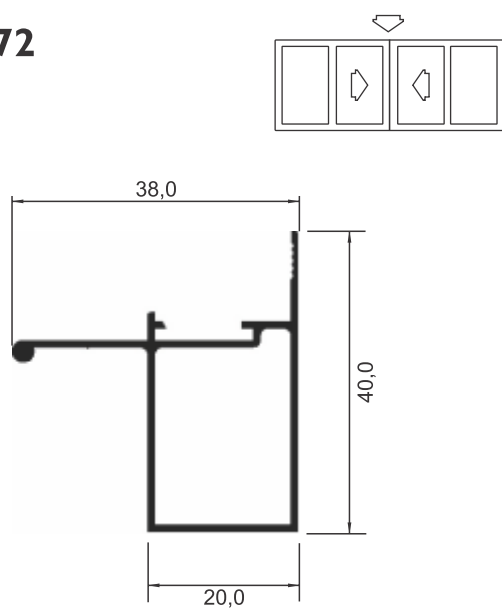

MP 374

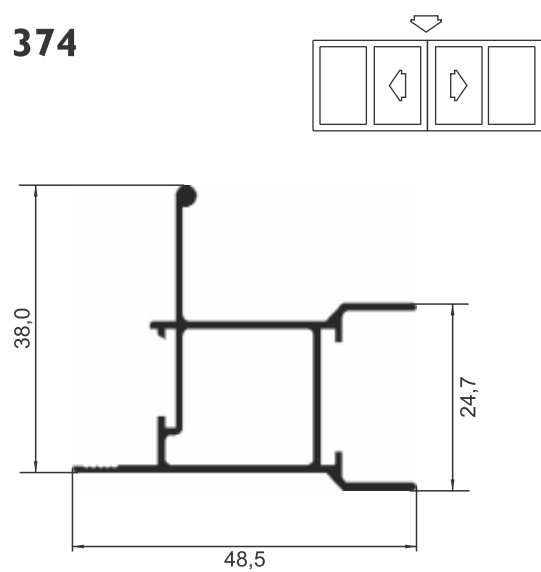

MP 336

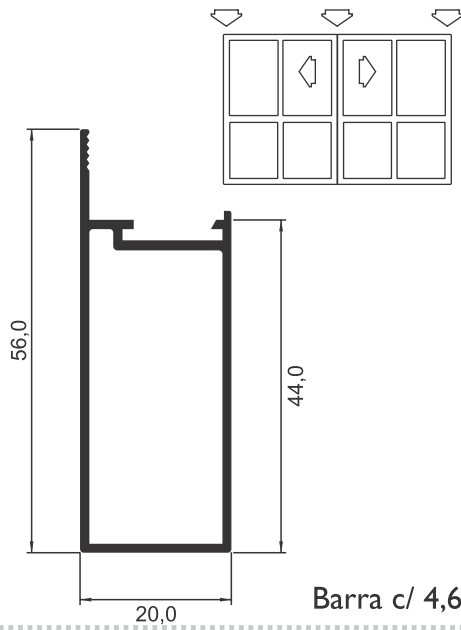

MP 332

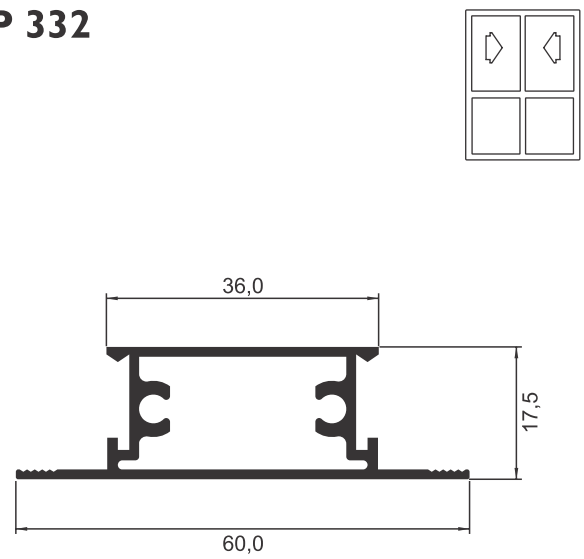

MP 069

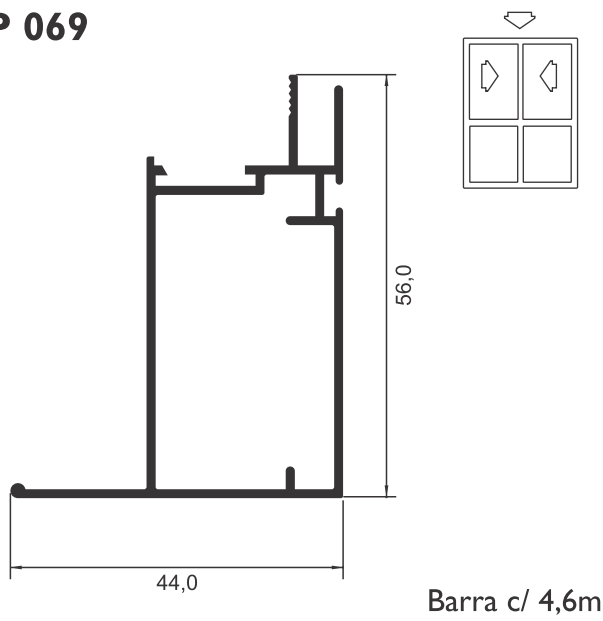

MP 070

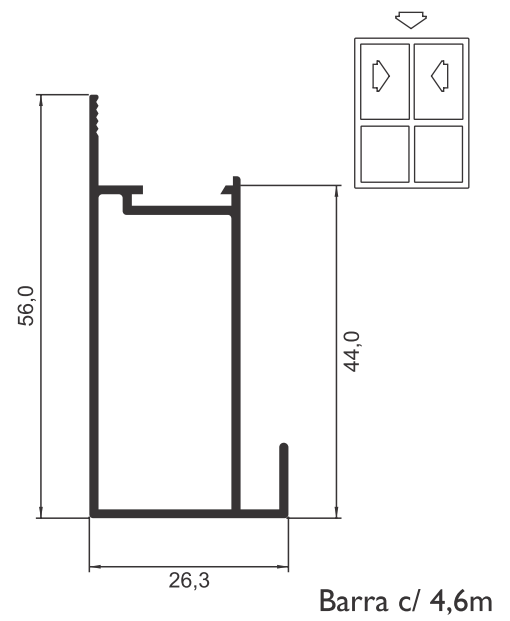

MP 337

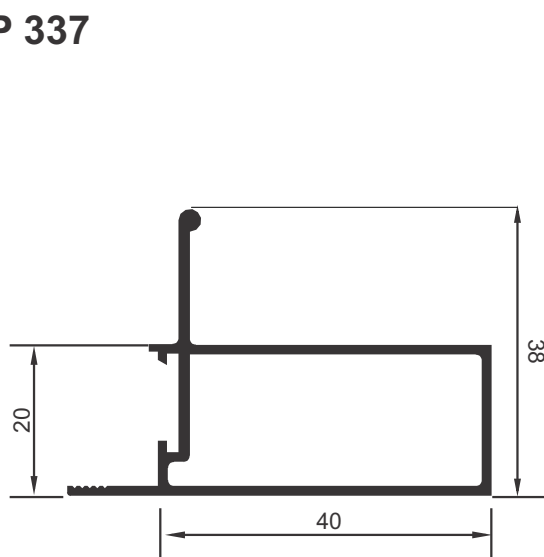

MP 363

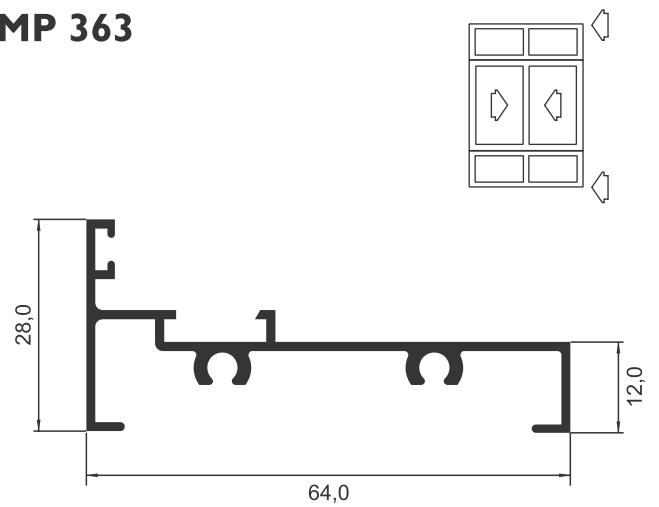

MP 357

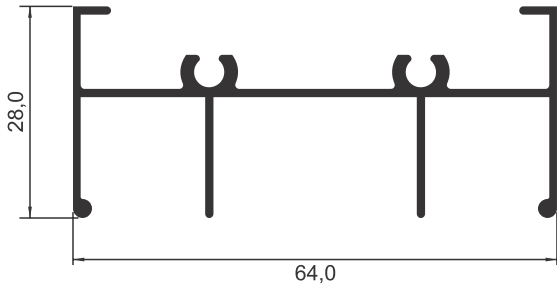
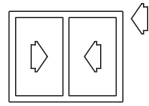

MP 358

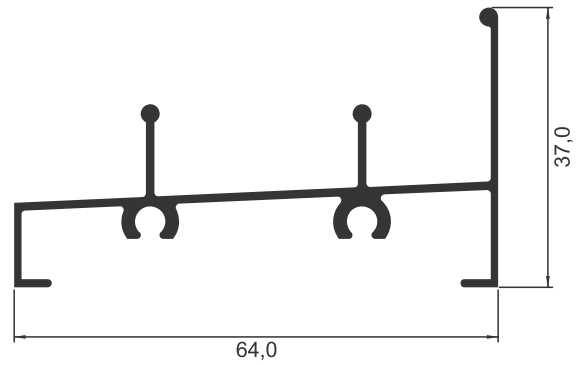
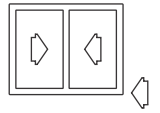

MP 360

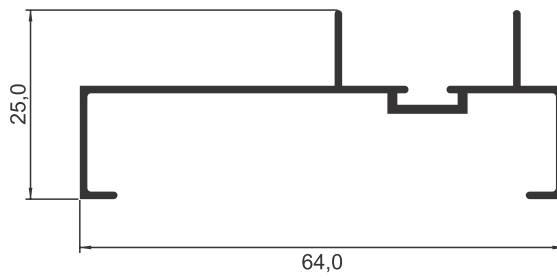
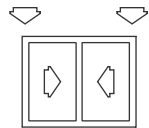

MP 359

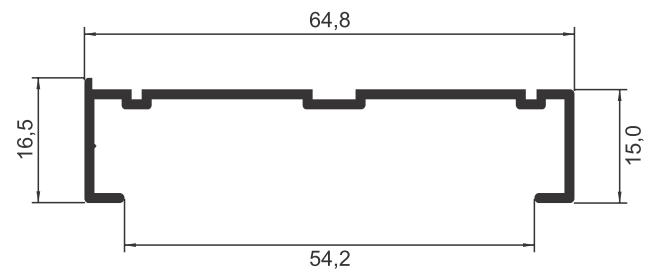
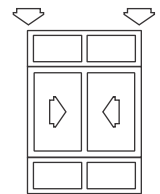

MP 352

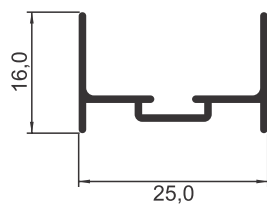
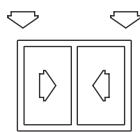

MP 370

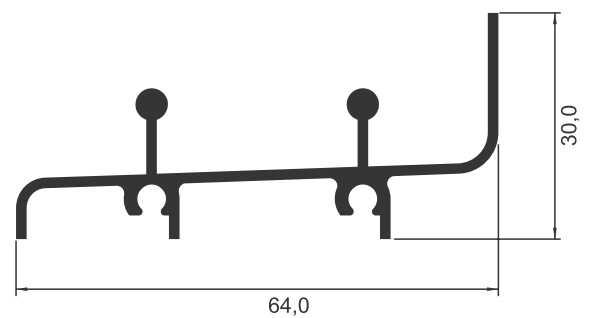
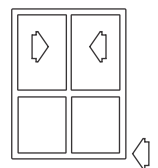

BG 202B

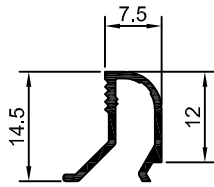

BG 202

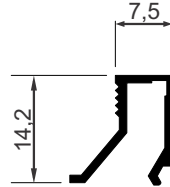

MP 347

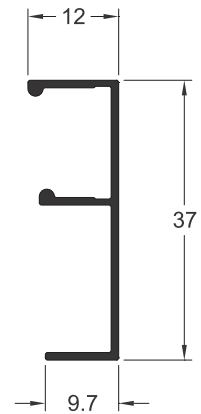

MP 354

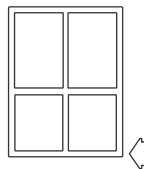
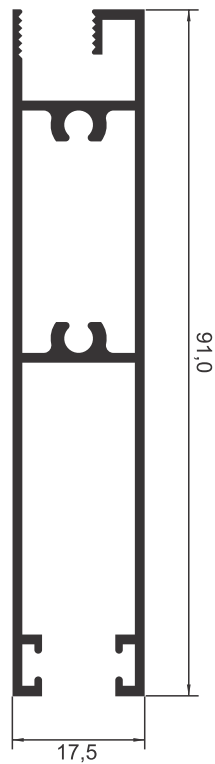

MP 361

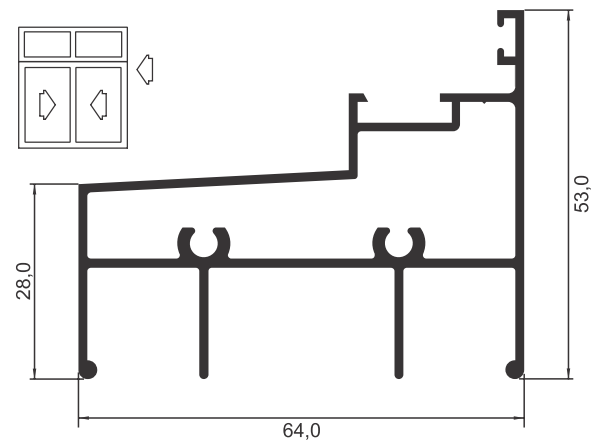

ME 013

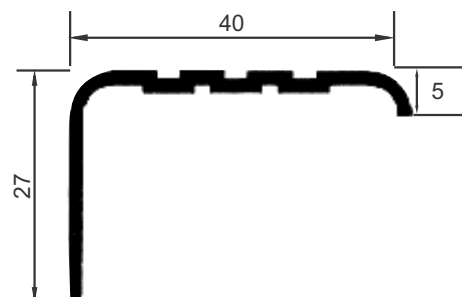

25 311

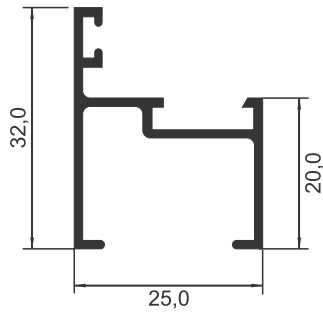
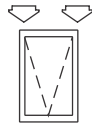

25 312

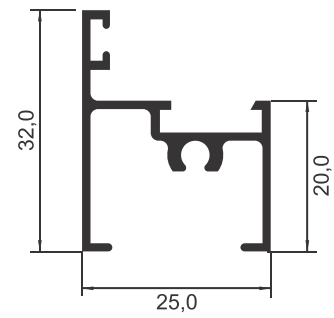
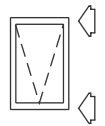

MM 376

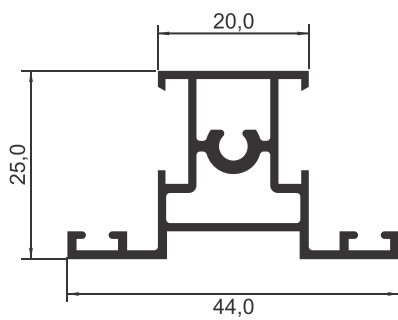
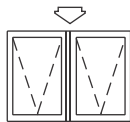

25 301

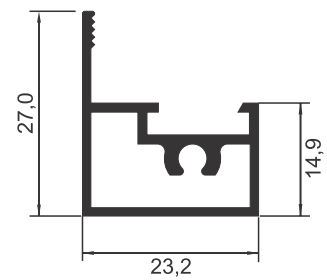
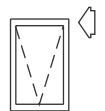

25 308

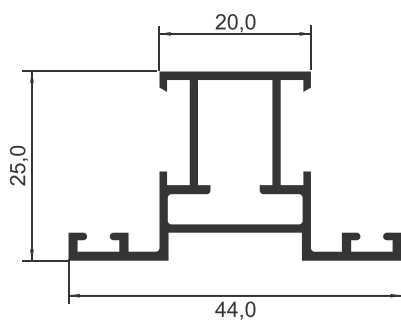
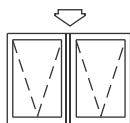

MM 375

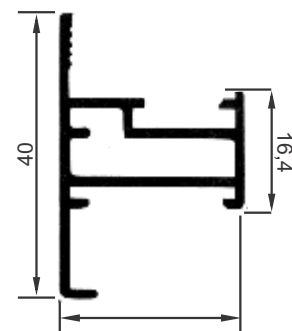

ME 056



BG 035

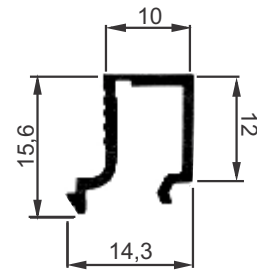
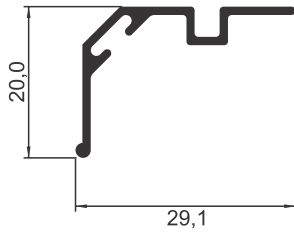

BG 035B

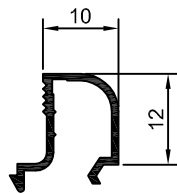

VZ 024

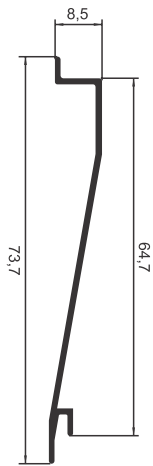

US 280

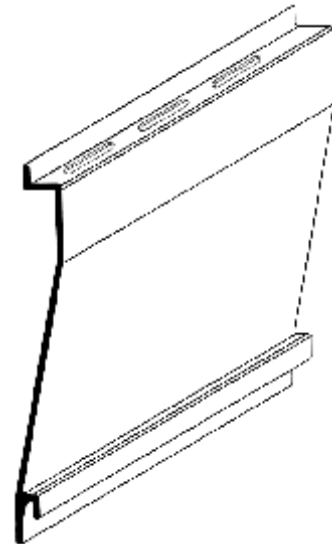

VZ 047

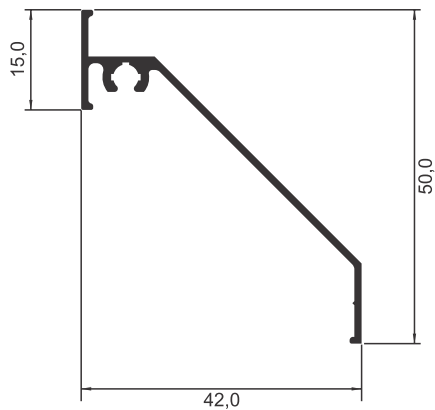

28 515

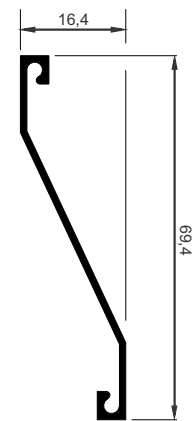

VZ 060

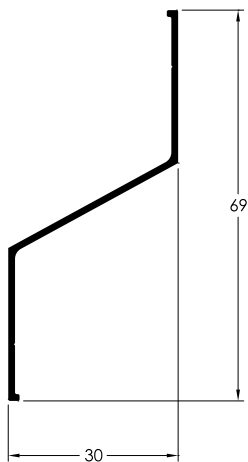

ECO 701

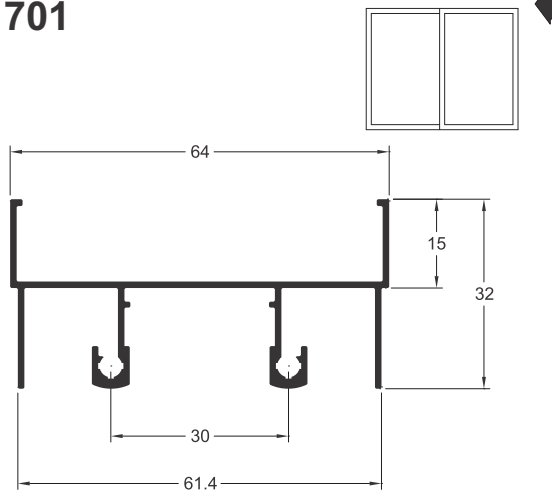

ECO 710

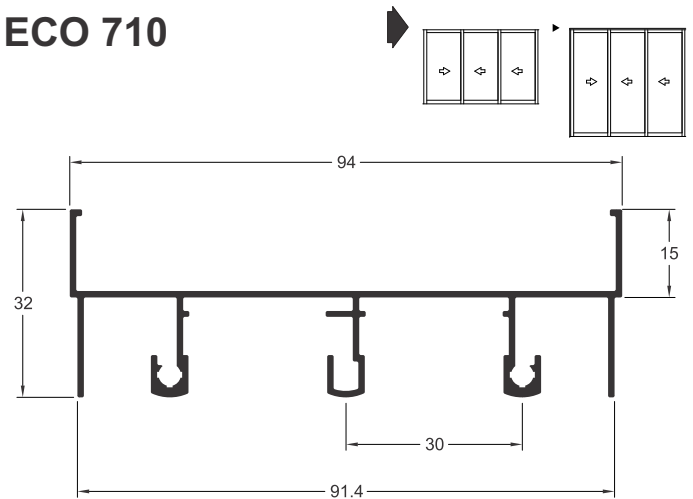

ECO 741

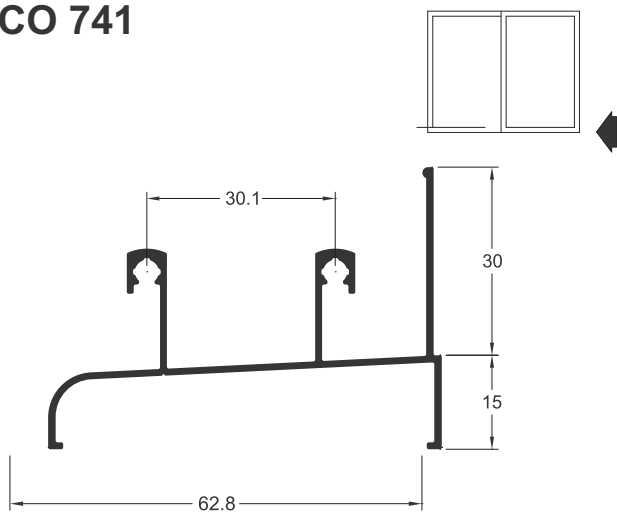

ECO 711

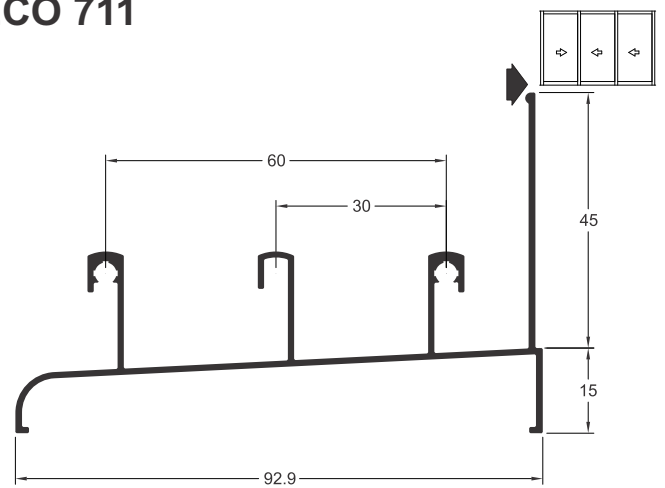

ECO 797

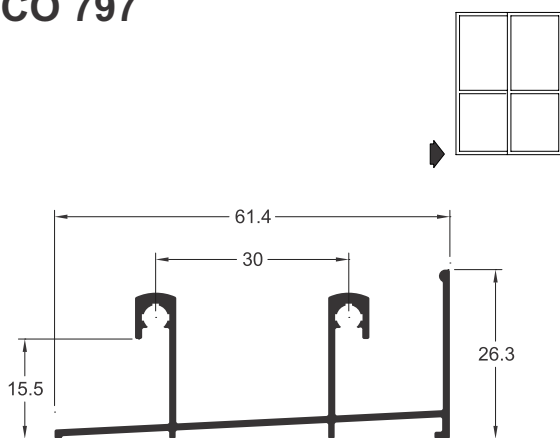

ECO 729

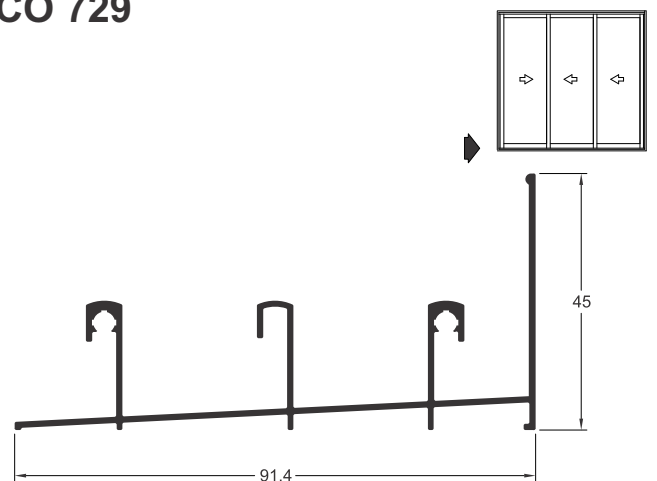

ECO 709

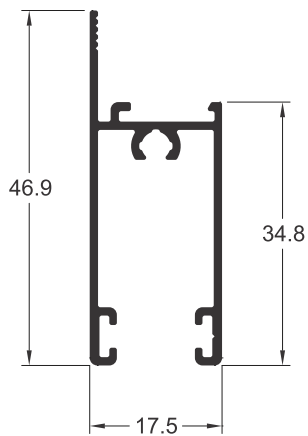

ECO 717

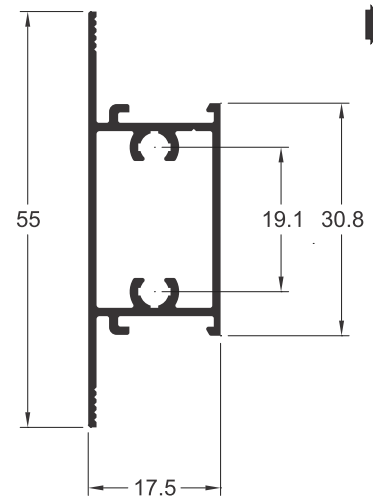

ECO 718

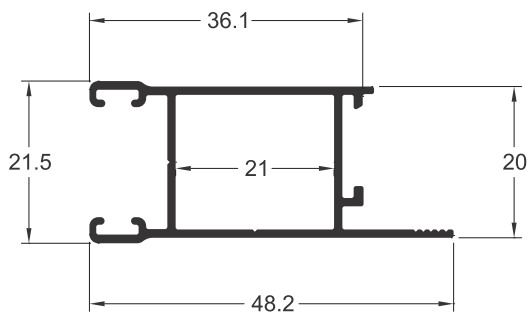

ECO 719

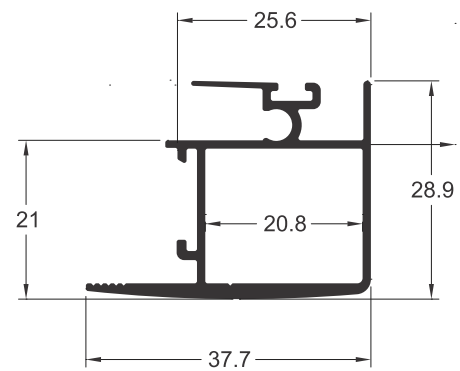

ECO 738

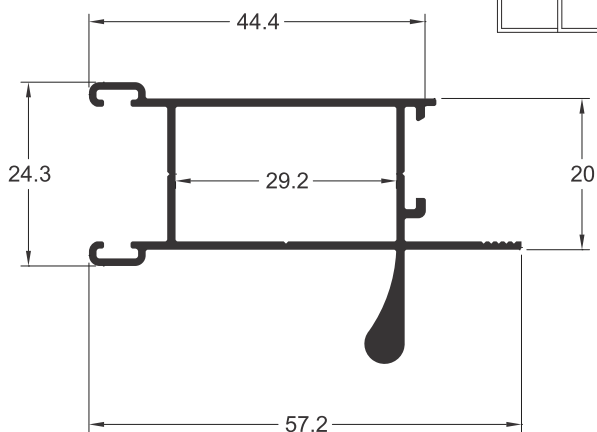

ECO 737

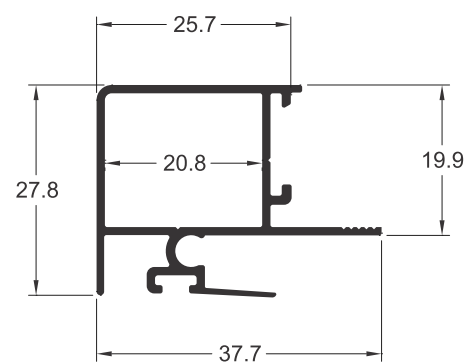

ECO 735

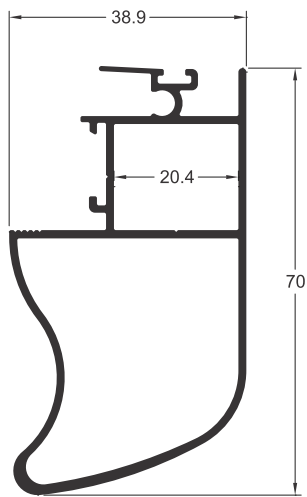

ECO 736

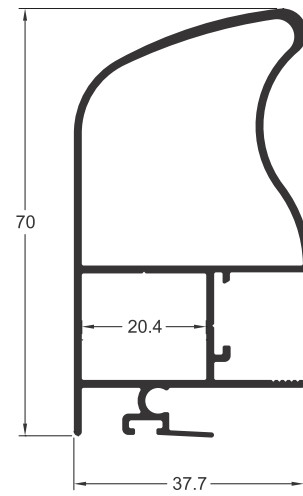

ECO 703

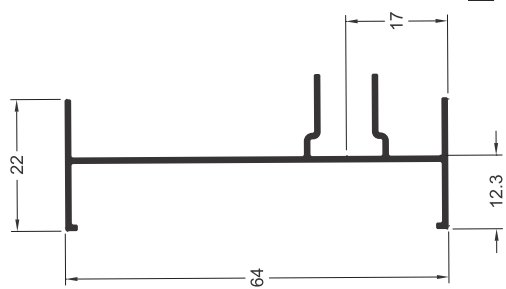

ECO 734

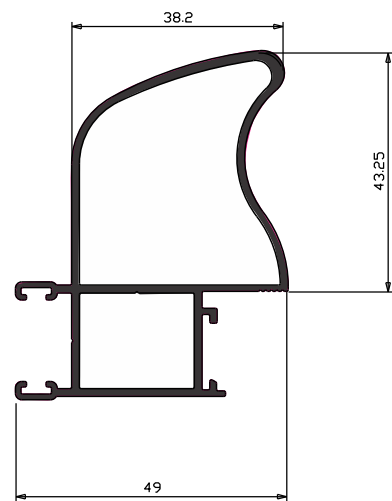

ECO 725

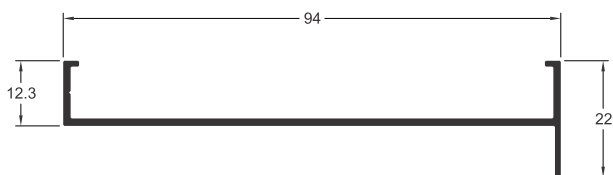

ECO 705

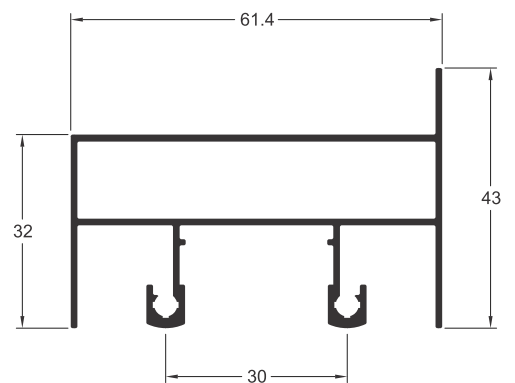

ECO 706

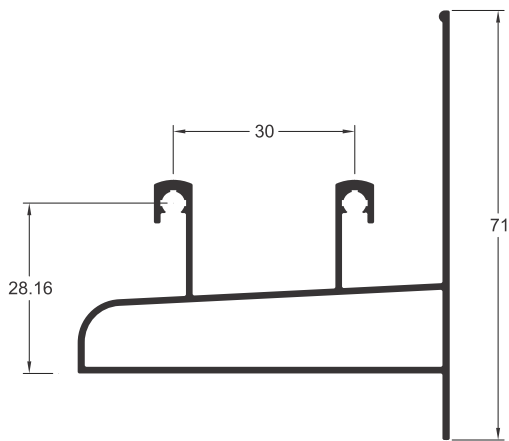

ECO 707

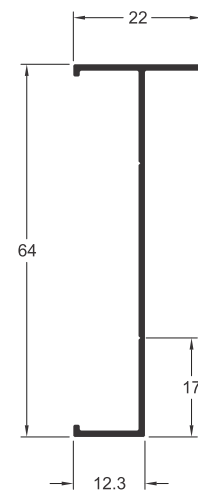

ECO 733

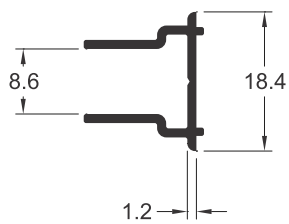
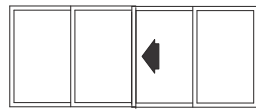

VT 302

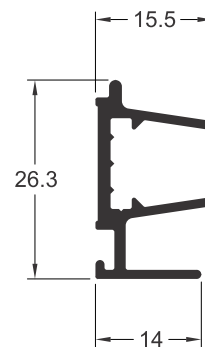
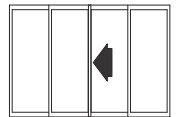

ECO 716

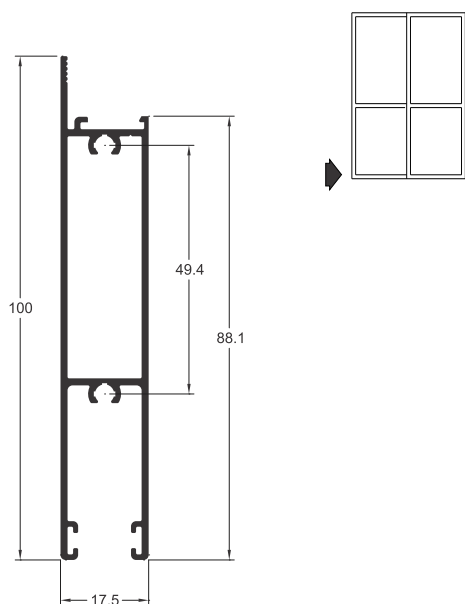

BG 202B

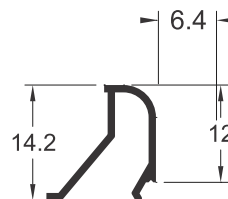

BG 202

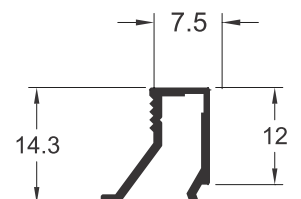

DIN 017

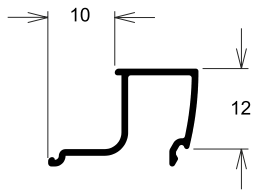

DIN 018

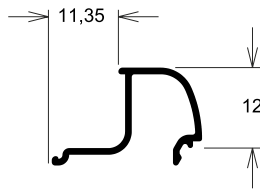

DIN 055

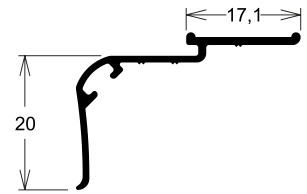

DIN 054

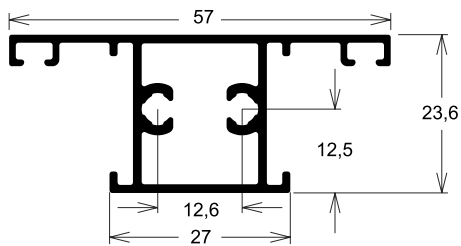

DIN 056

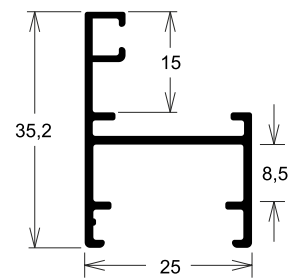

DIN 058

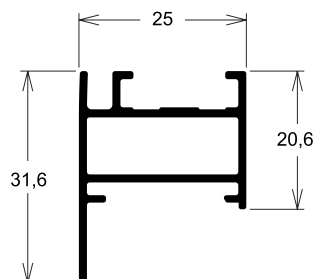

DIN 061

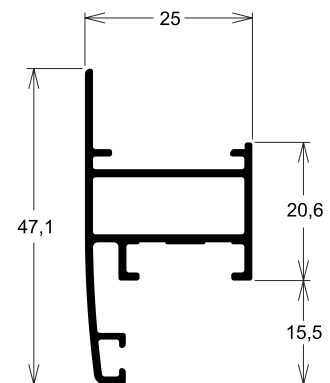

DIN 065

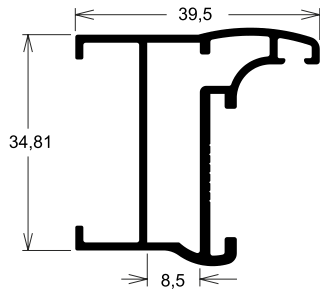

DIN 066

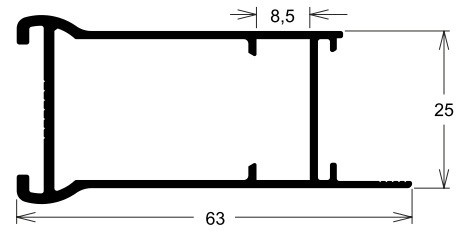

DIN 015

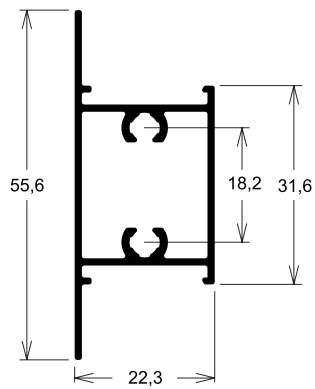

LG 044

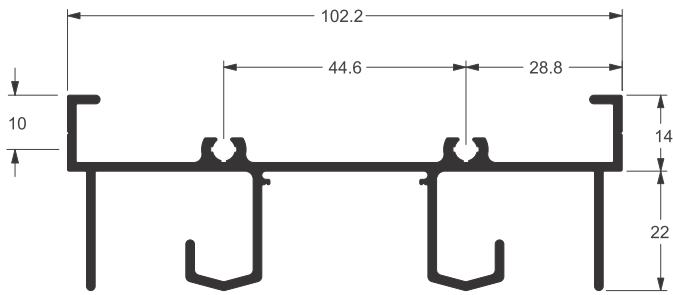

LG 047

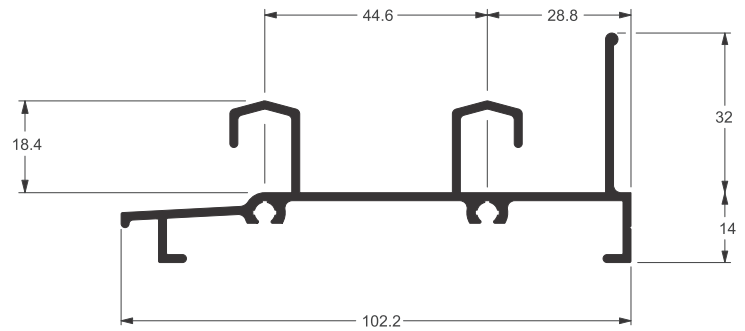

LG 062

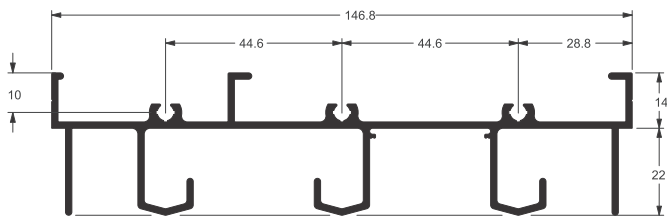

LG 066

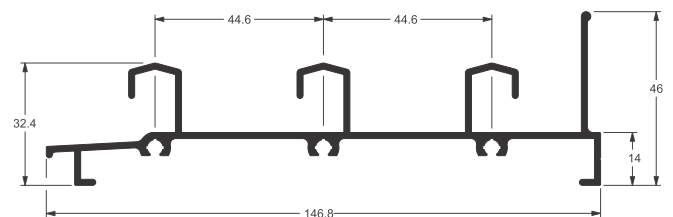

LG 070

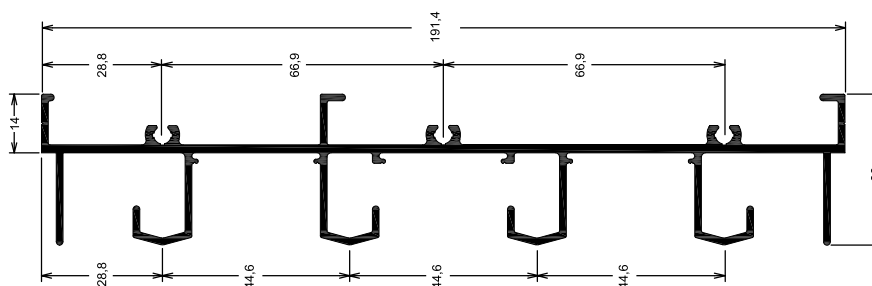

LG 159

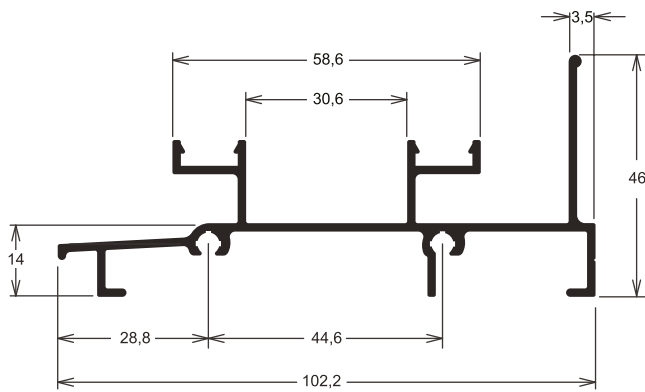

LG 111

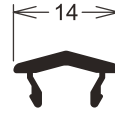

DPR 003

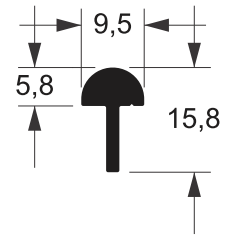

LG 116

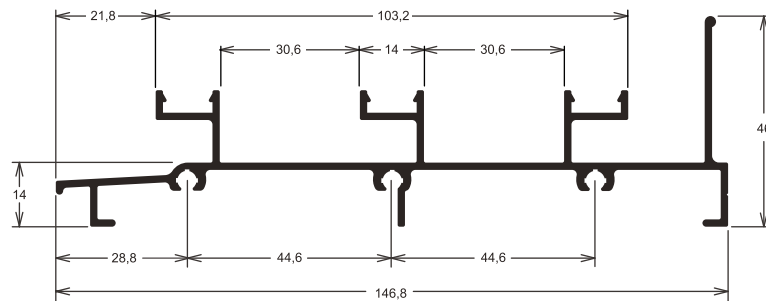

LG 160

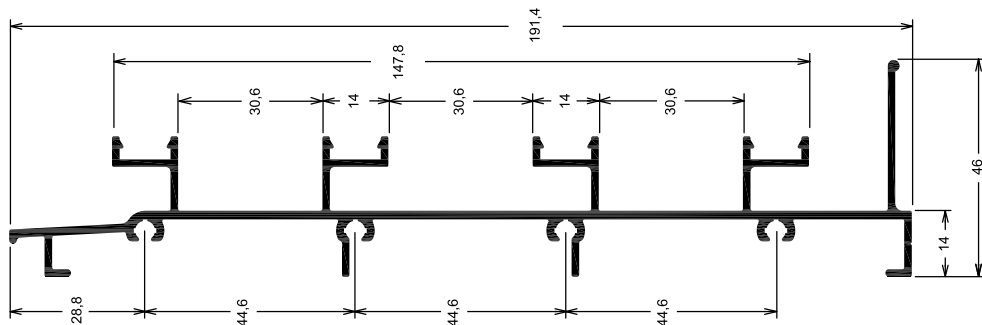

LG 072

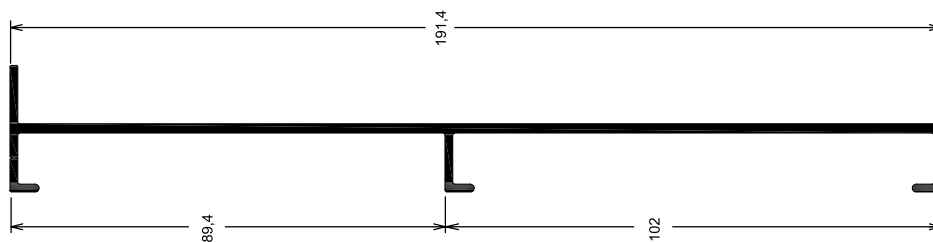

LG 003

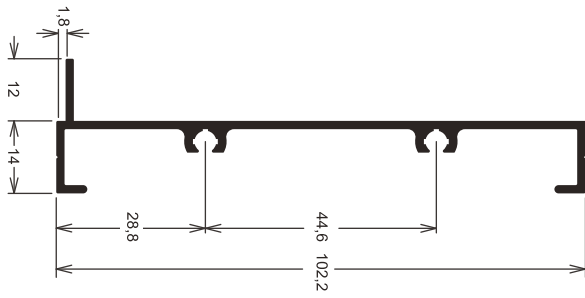

LG 002

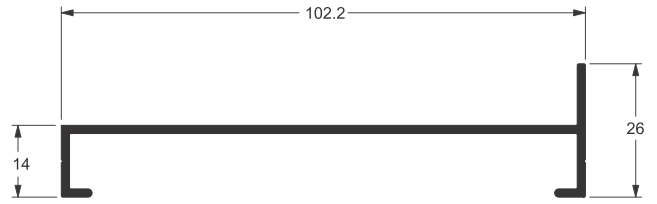

LG 158

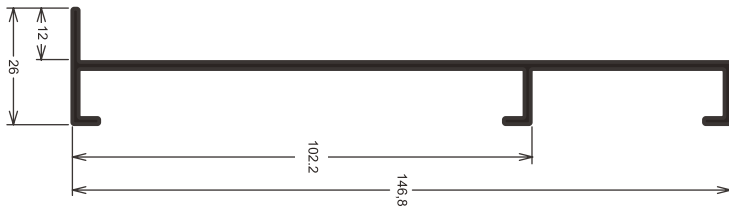

LG 028

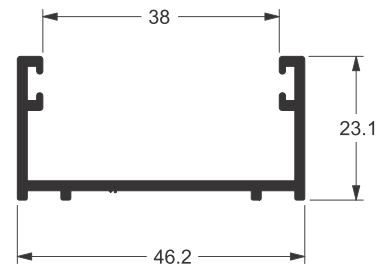

LG 057

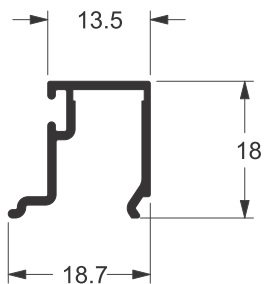

LG 026

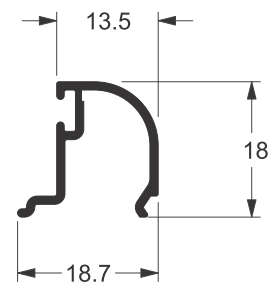

LG 006

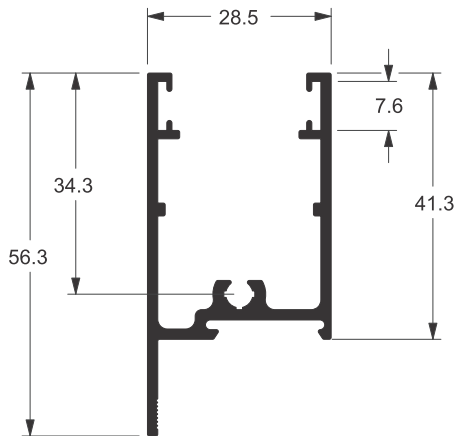

LG 007

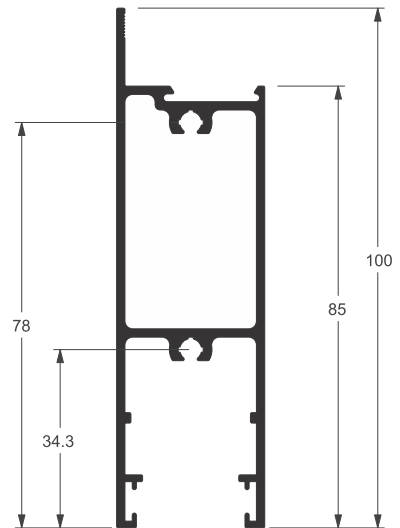

LG 055

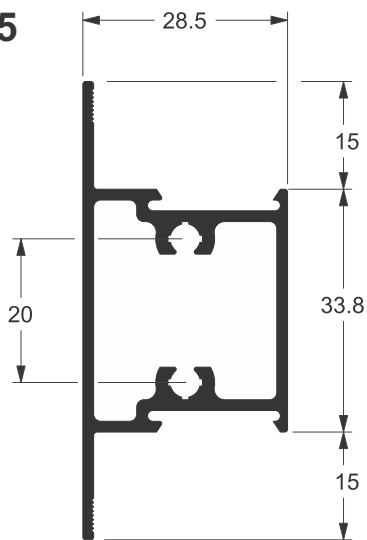

LG 049

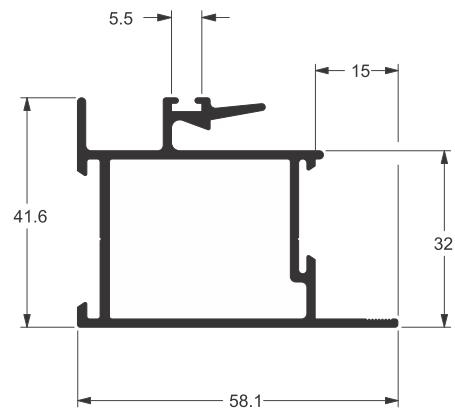

LG 048

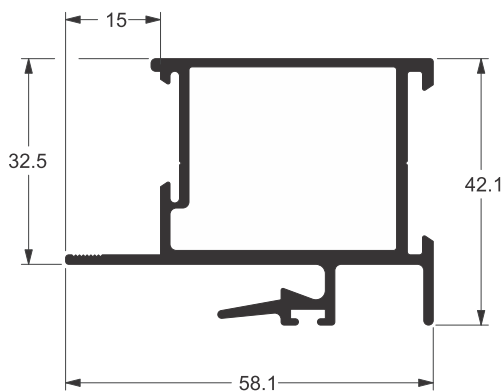

LG 050

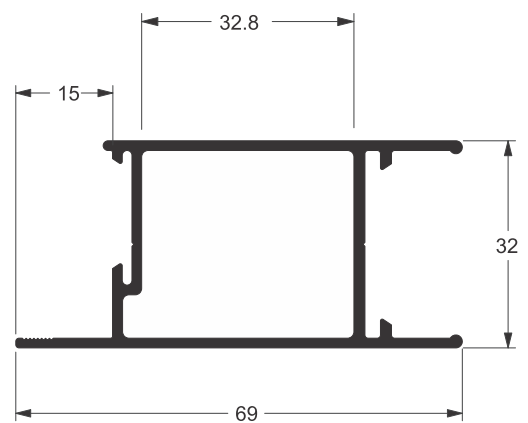

LG 051

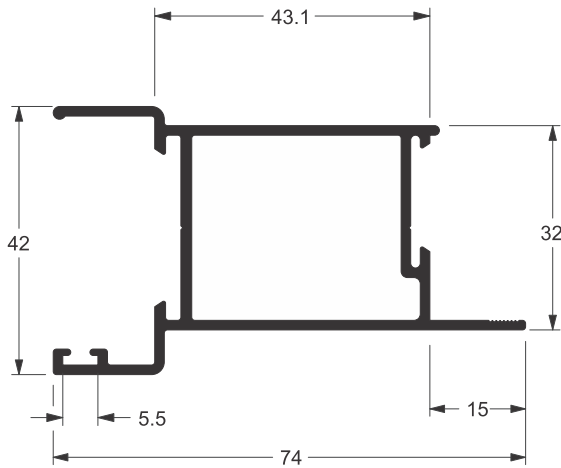

LG 020

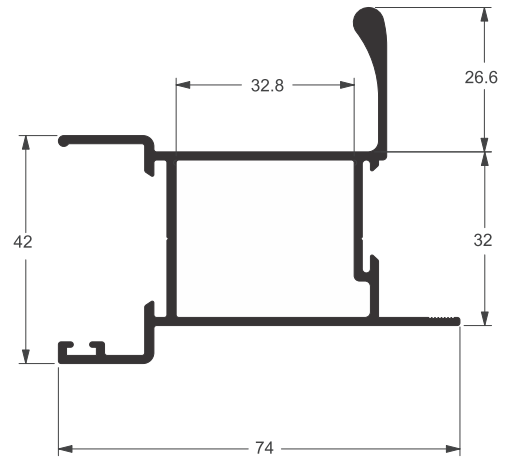

LG 017

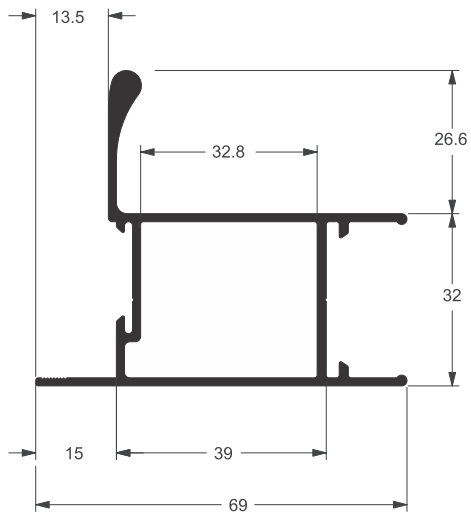

LG 021

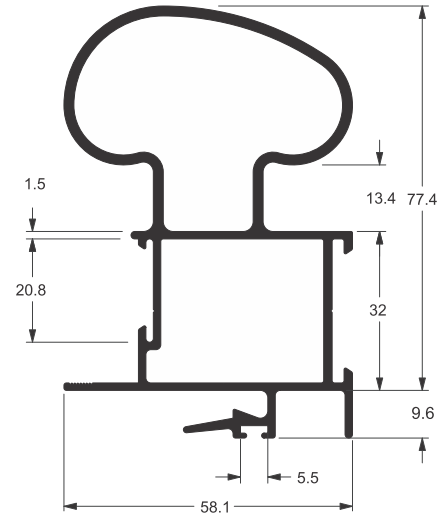

LG 137

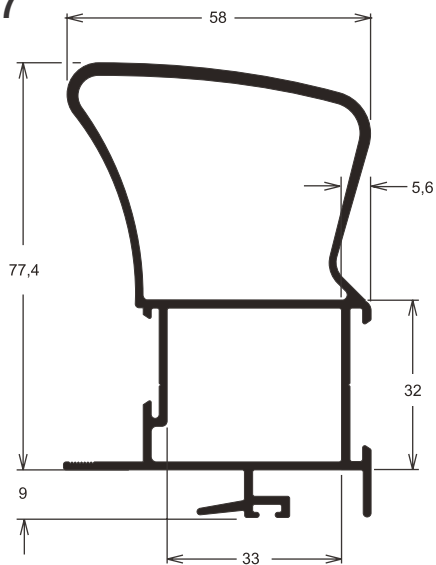

LG 140

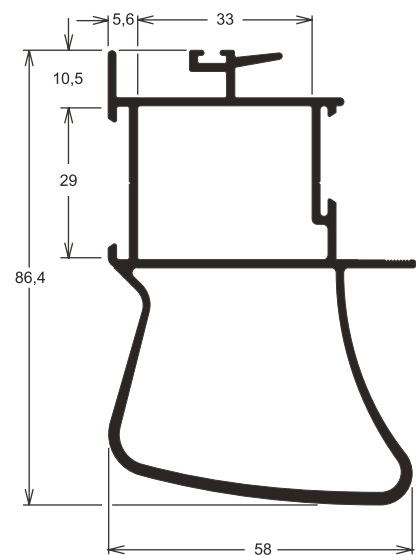

LG 042

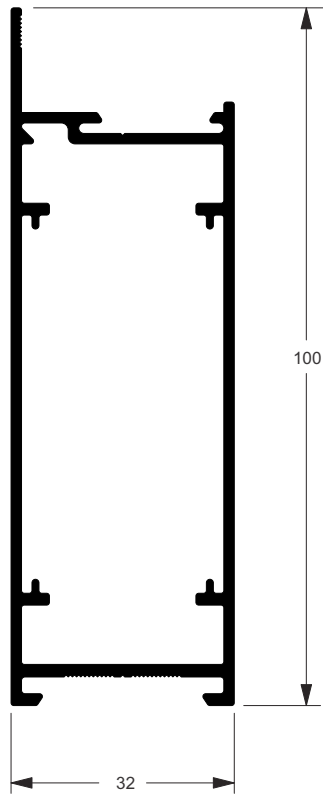

LG 043

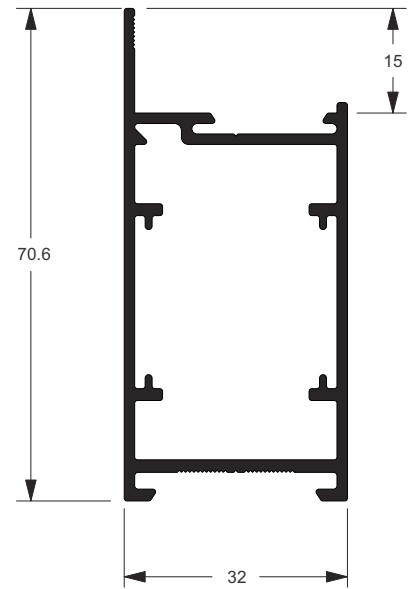

LG 056

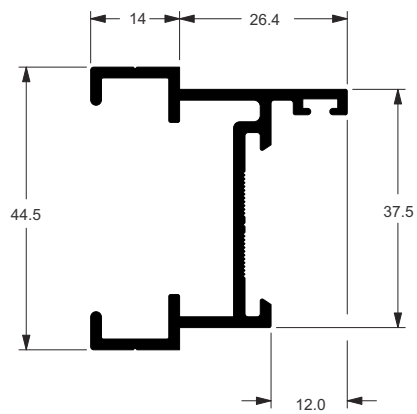

LG 016

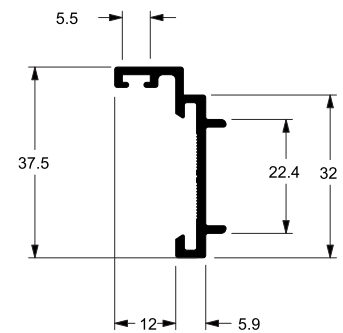

DPR 007

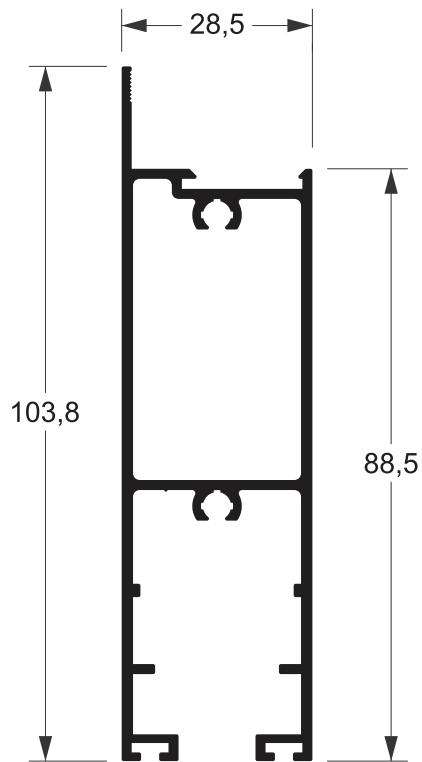

LG 004

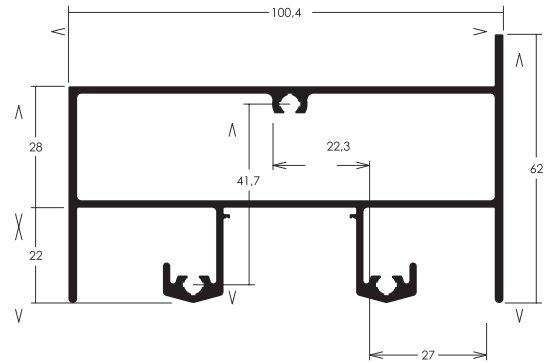

LG 117

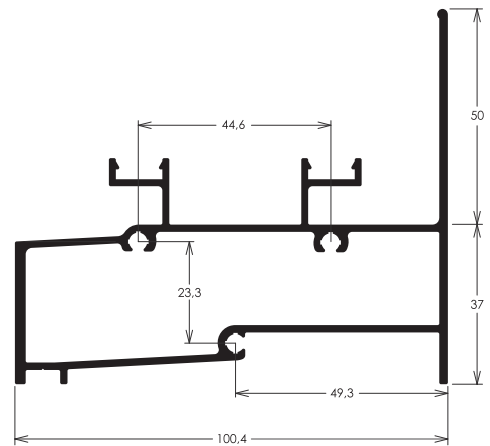

LG 005

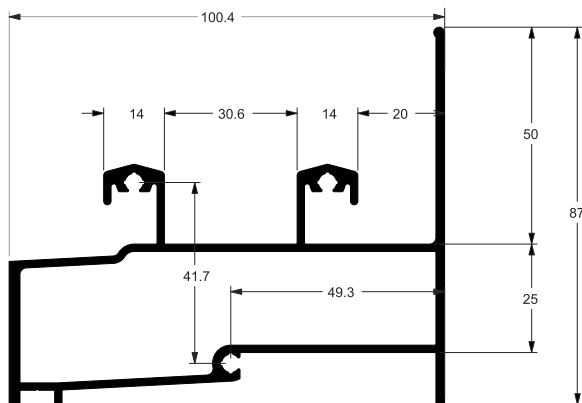

LG 068

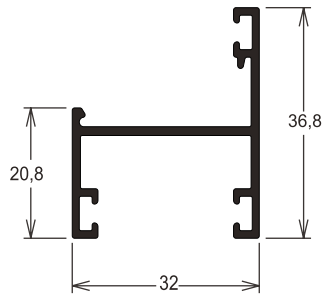

LG 083

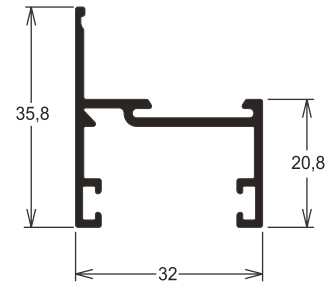

LG 074

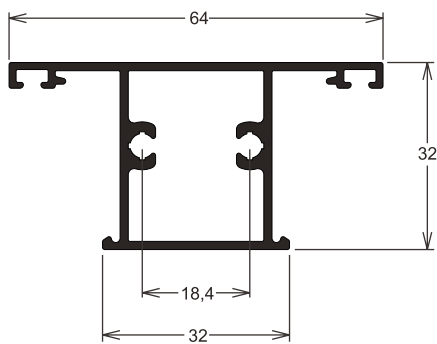

LG 085

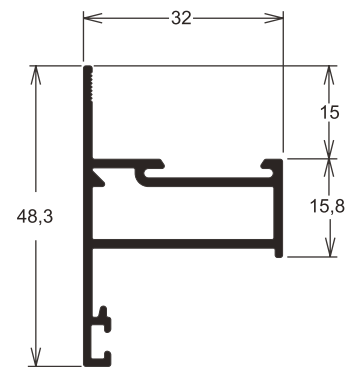

LG 091

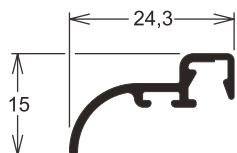

LG 058

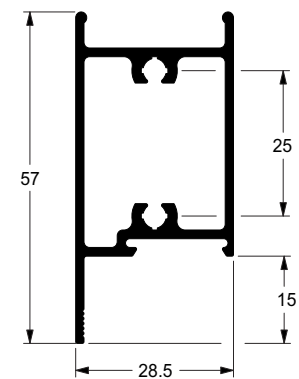

BX 185

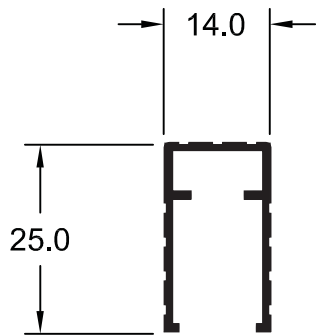

BX 159

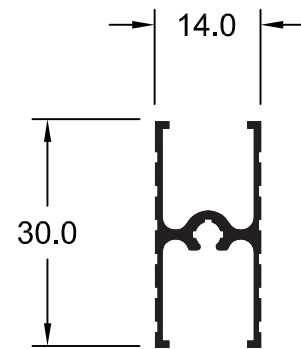

BX 188

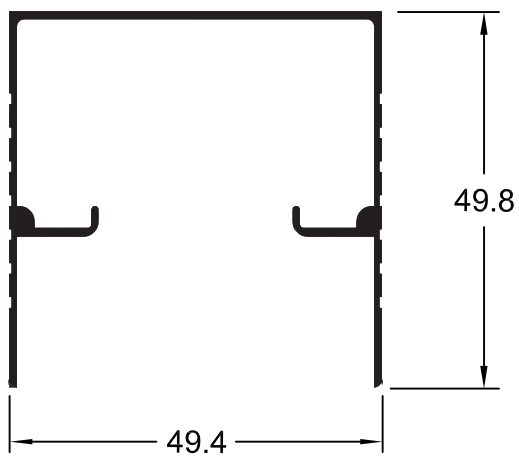

BX 175

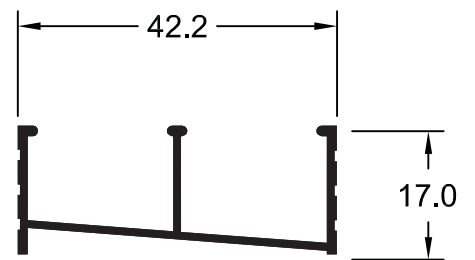

BX 174

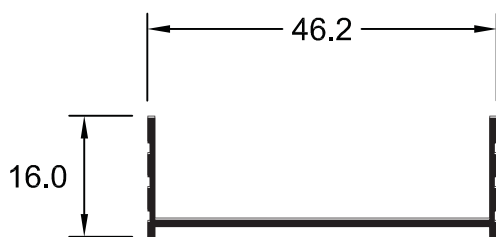

BX 106

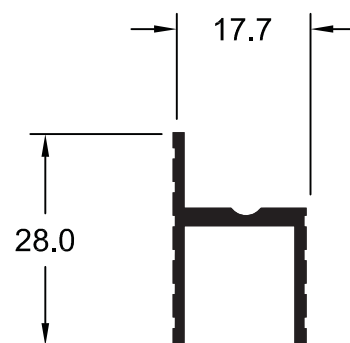

BX 170

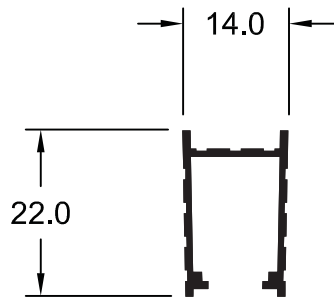

BX 168

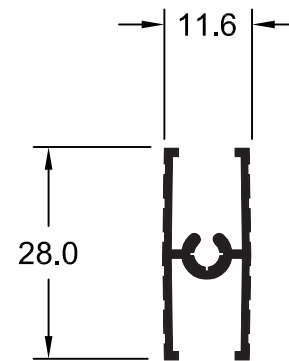

BX 171

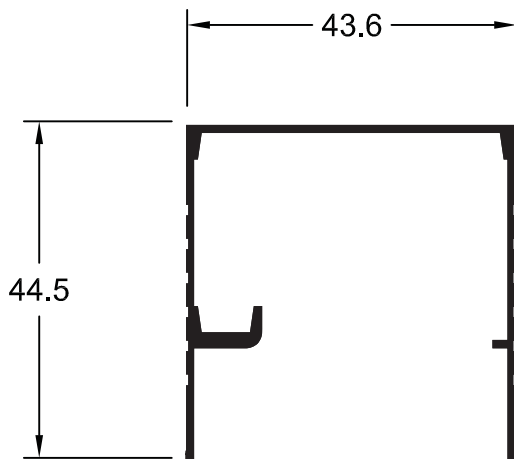

BX 169

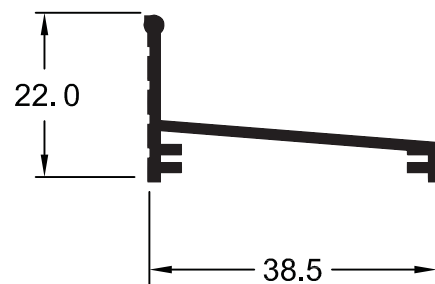

BX 172

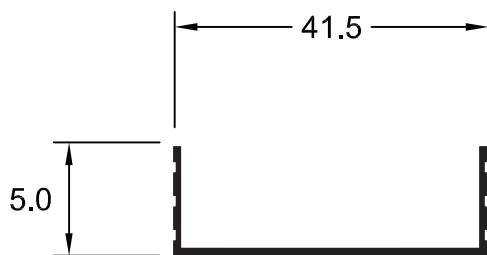

BX 112

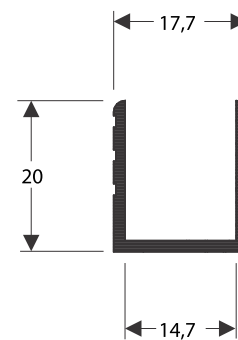

DSP 049

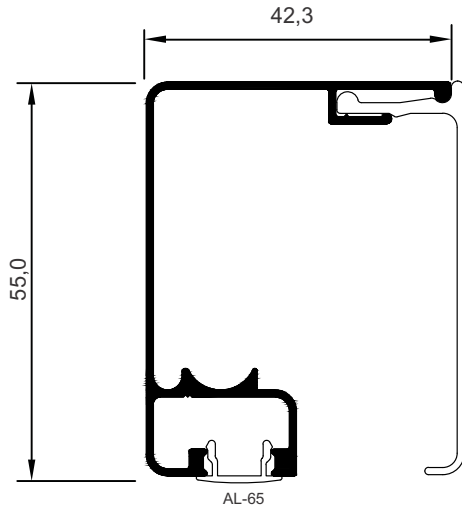

DSP 050

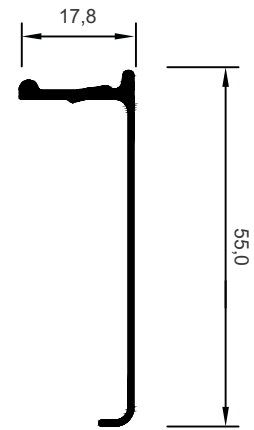

DSP 051

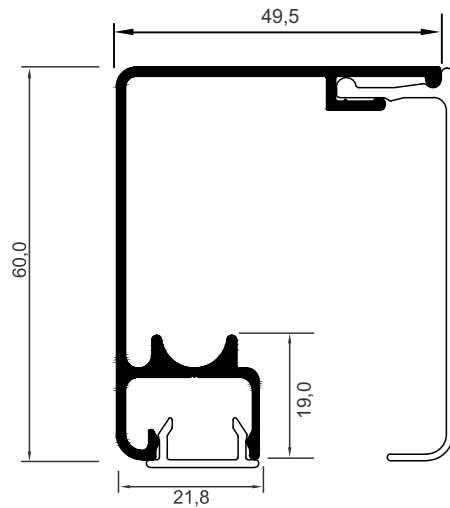

DSP 052

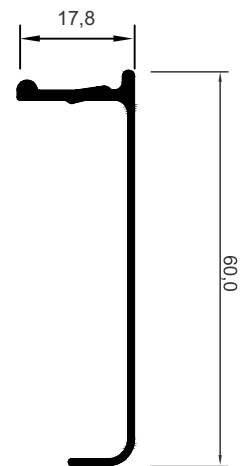

DSP 252

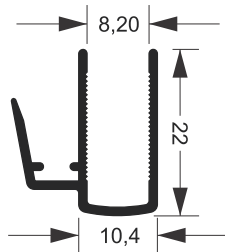

DSP 253

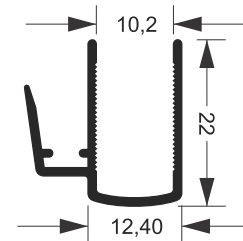

AL 49

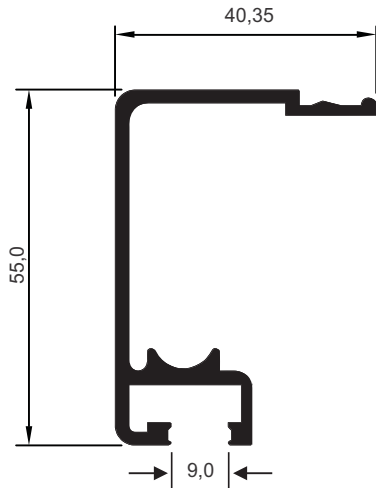

AL 50

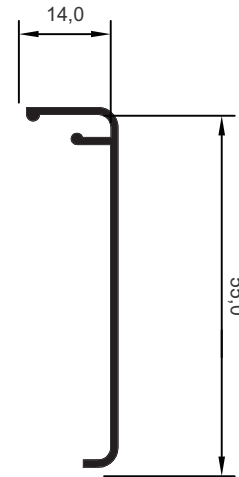

AL 75

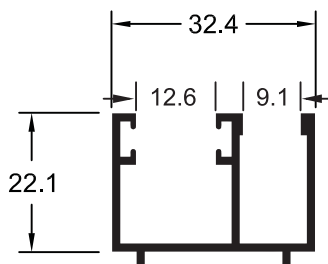

AL 65

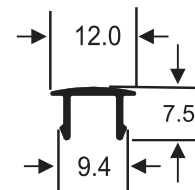

AL 63

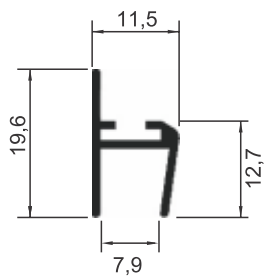

AL 46

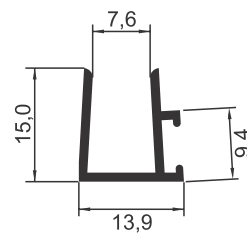

AL 15

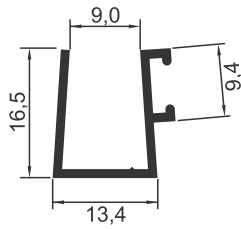

AL 16

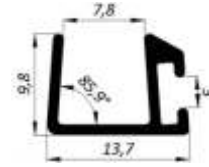

AL 47

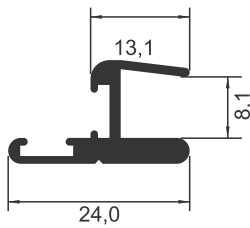

AL 64

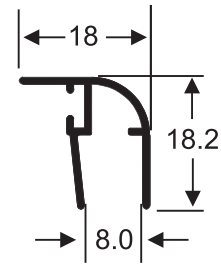

AL 86

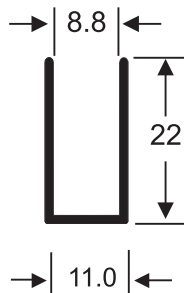

AL 87

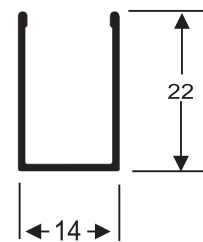

AL 01

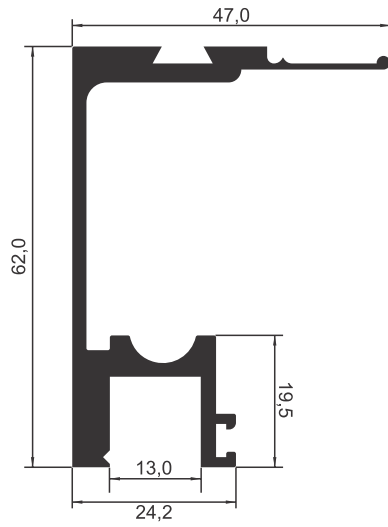

AL 02

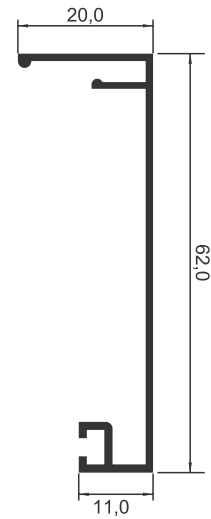

AL 51

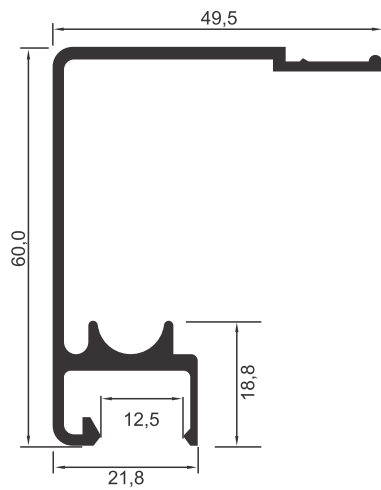

AL 52

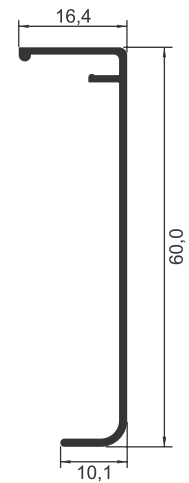

AL 05

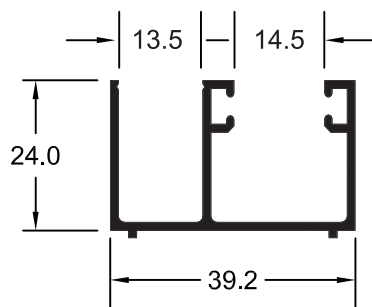

AL 13

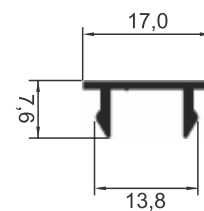

AL 17

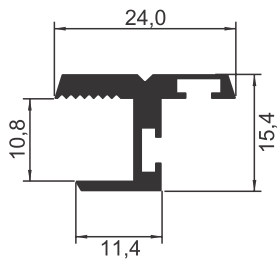

AL 11

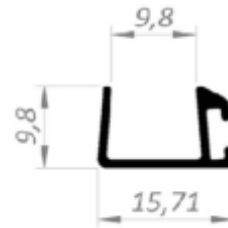

AL 14

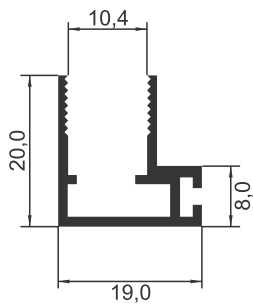

AL 62

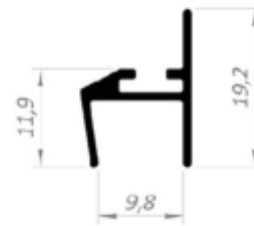

AL 10

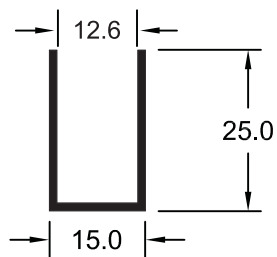

AL 22

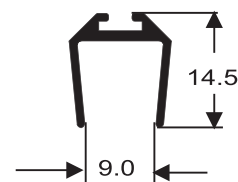

AL 06

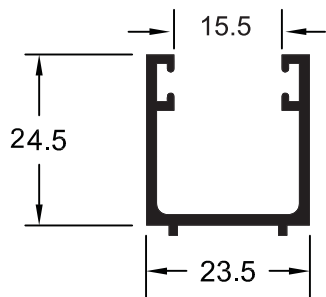

AL 09

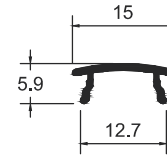

AL 300

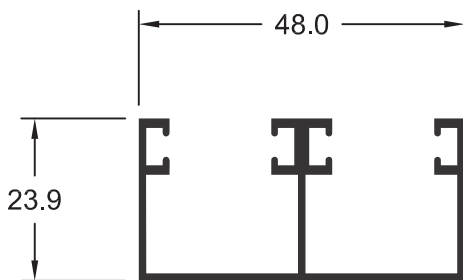

AL 500

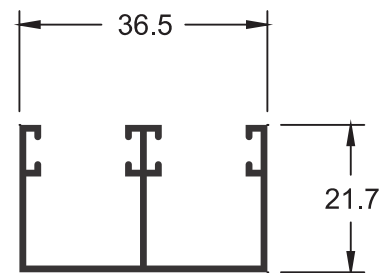

AL 80

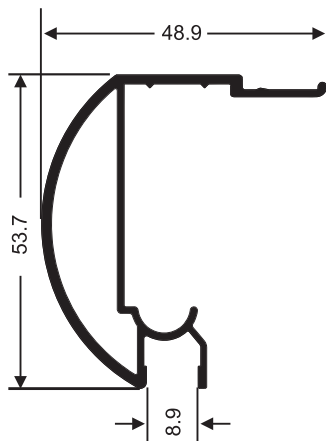

AL 81

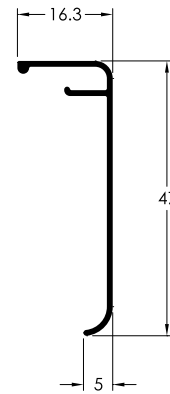

AL 82

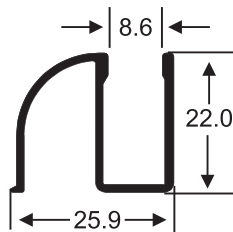

AL 83

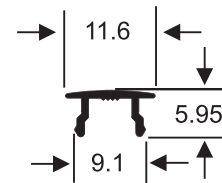

AL 86

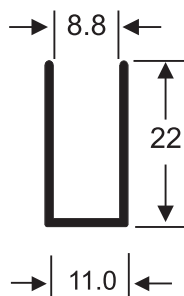

AL 87

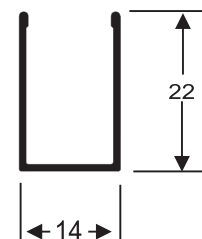

AL 68

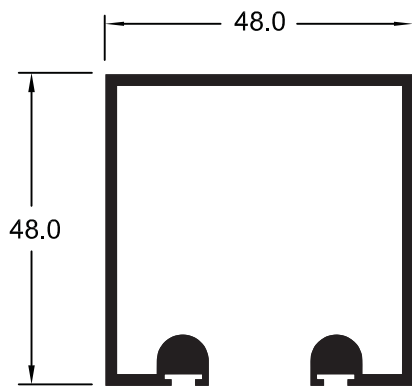

AL 37

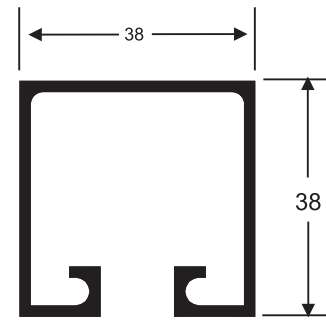

AL 89

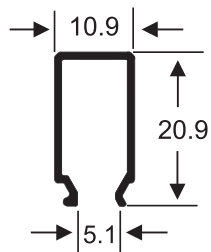

AL 88

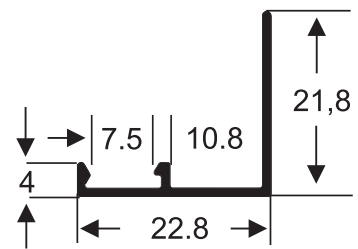

AL 26

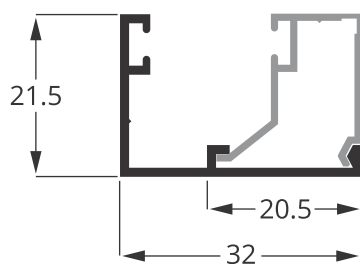

AL 27

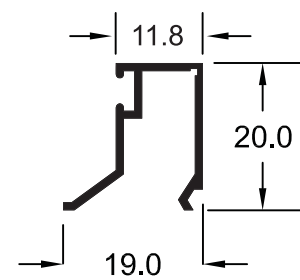

AL 90

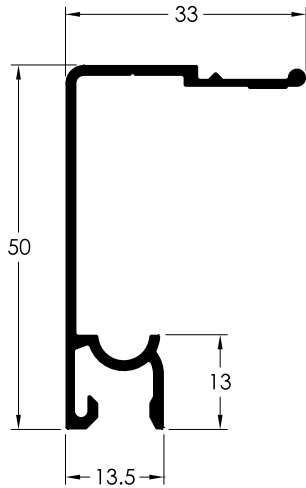

AL 91

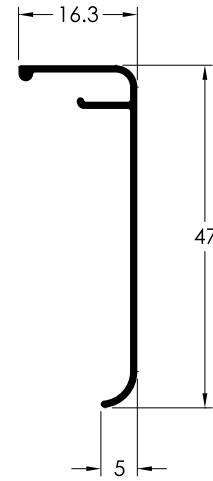

AL 92

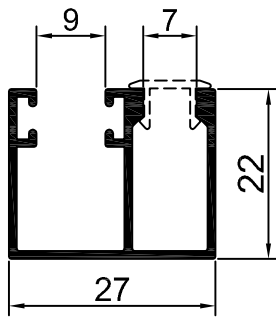

AL 93

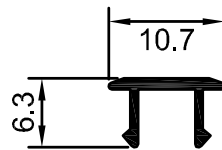

AL 94

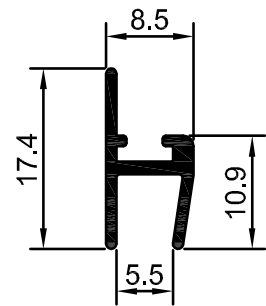

AL 95

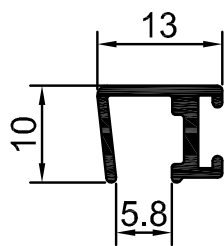

AL 96

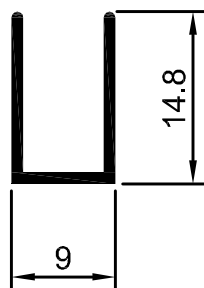

AL 44

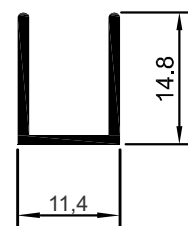

TG 005

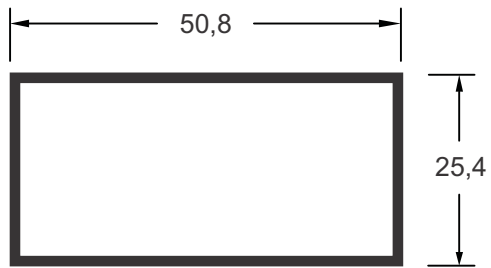

TQ 017

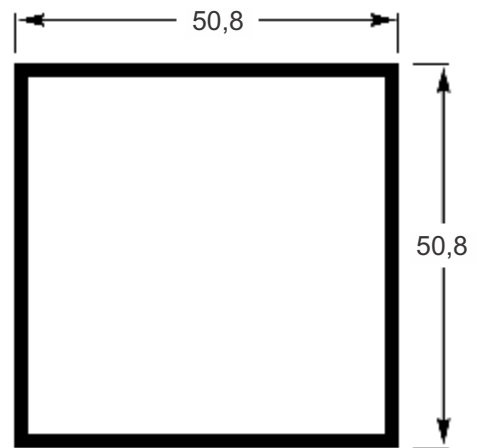

TG 038

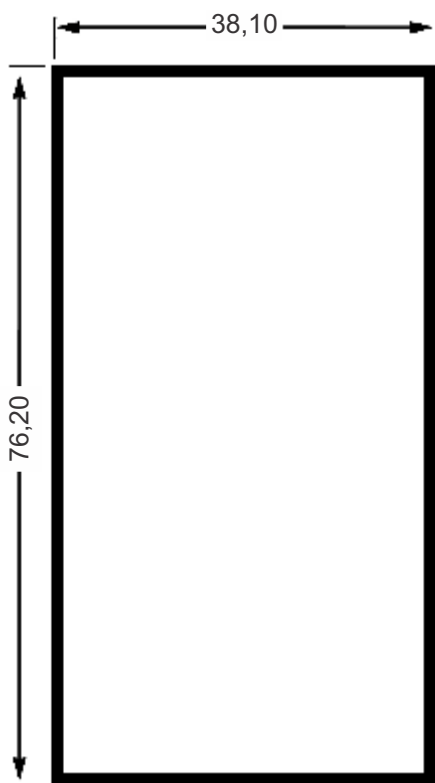

TG 019

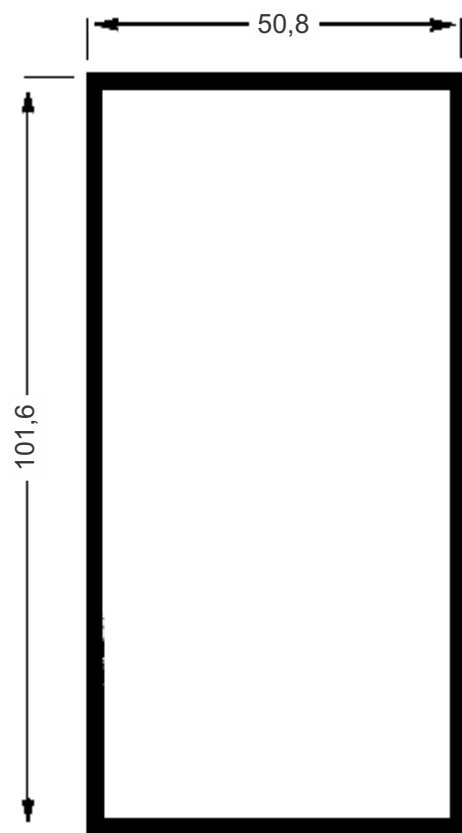

CV - 027

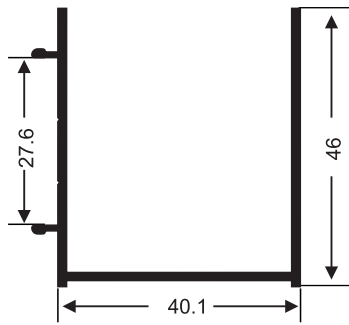

CV - 026

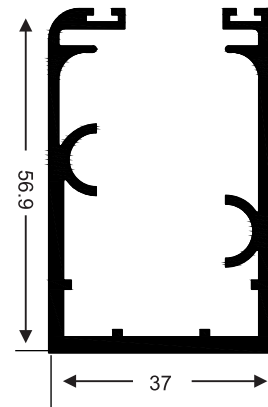

CV - 025

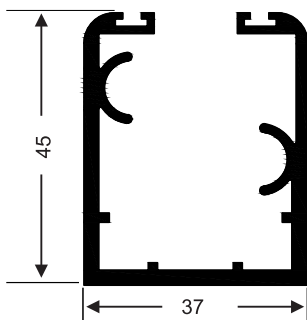

CV - 028

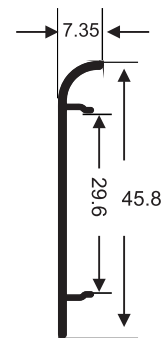

CV - 083

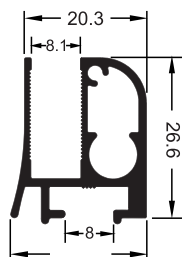

CV - 084

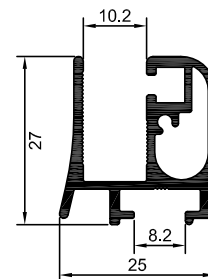

CG 083

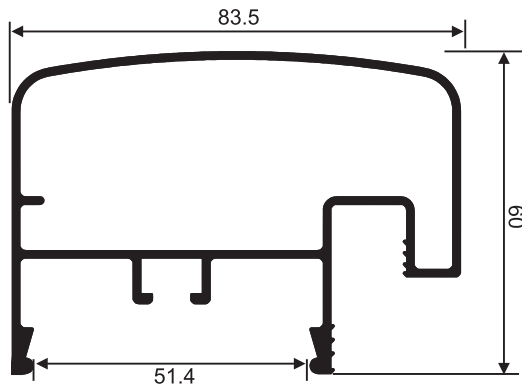

CG 013

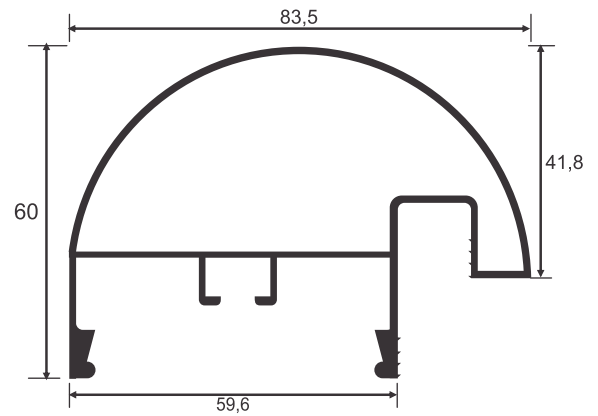

CG 077

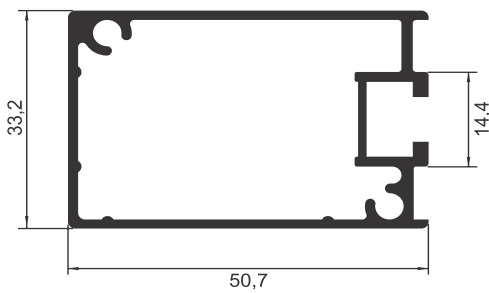

CG 075

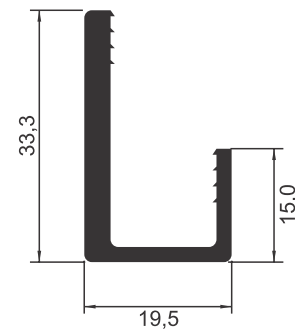

CG 074

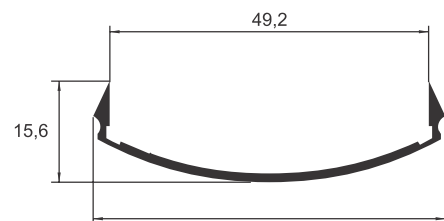

D 0094

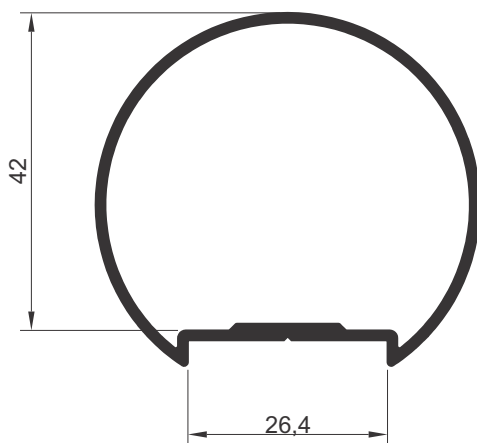

CG 003

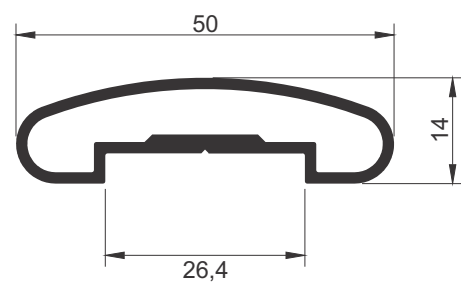

CG 219

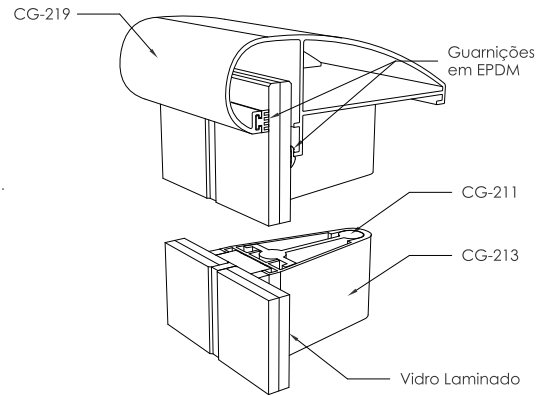
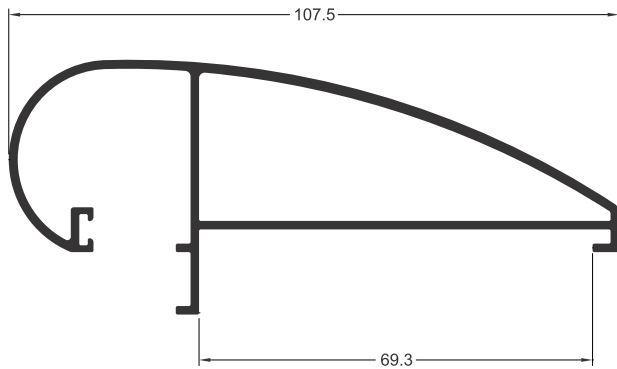

CG 204

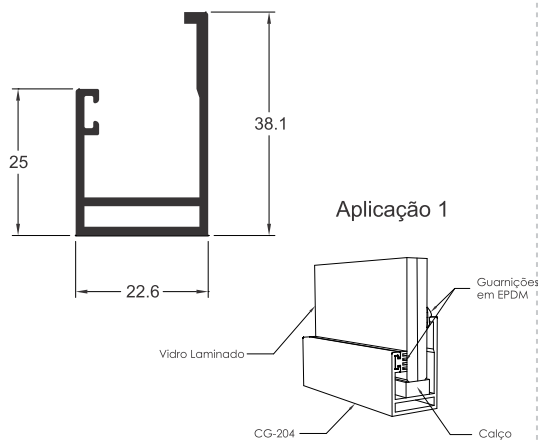

CG 213

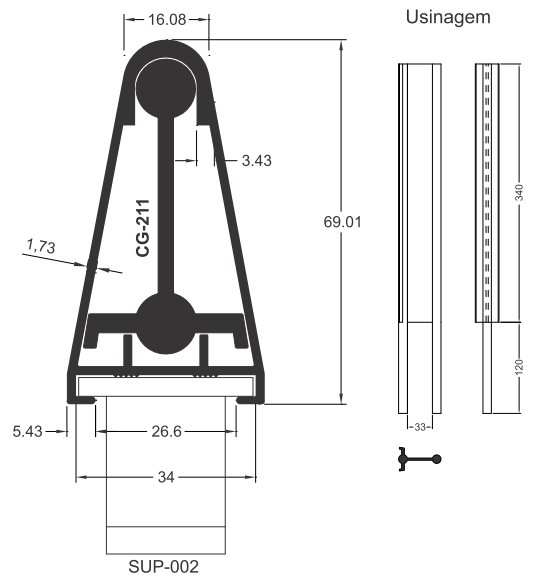

CG 171

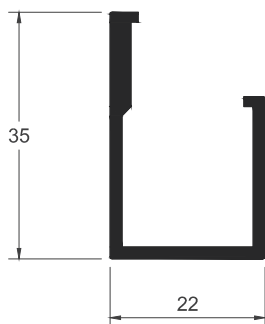

TPS 039

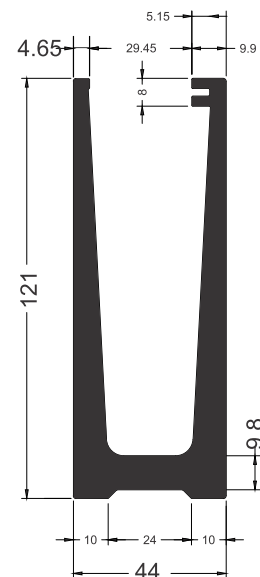

N 0012

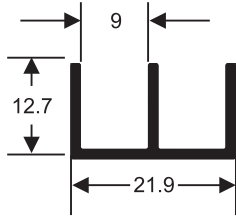

N 0042



BK 024

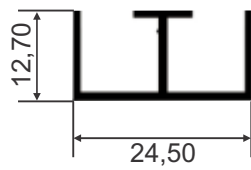

N 0009

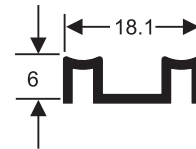

BK 026

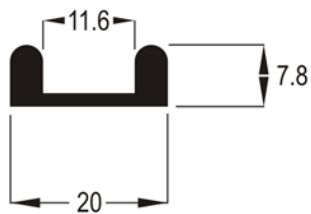

BK 023

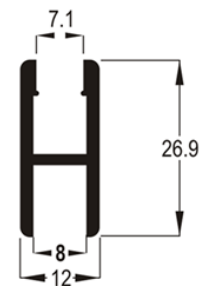

LB 050

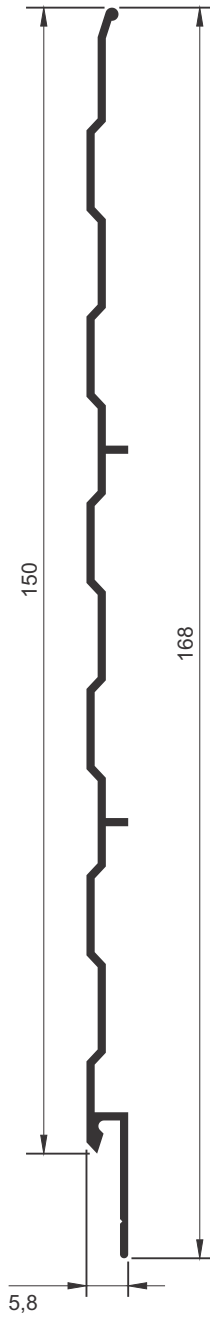

LB 036

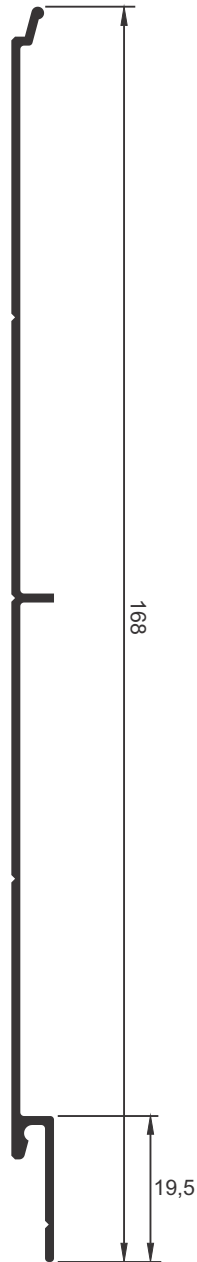

LB 010

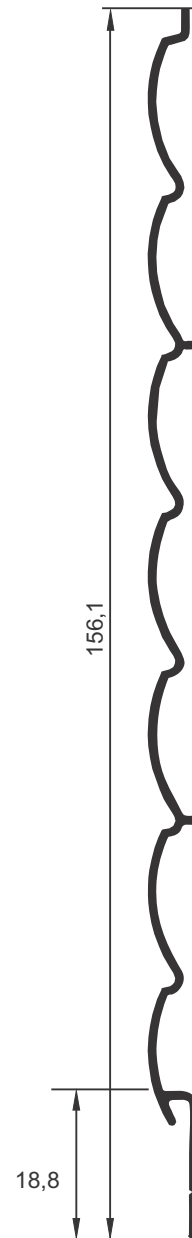

LB 030

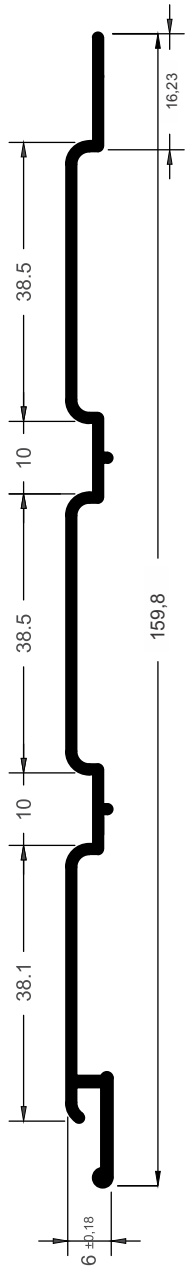

LB 600



LB 602

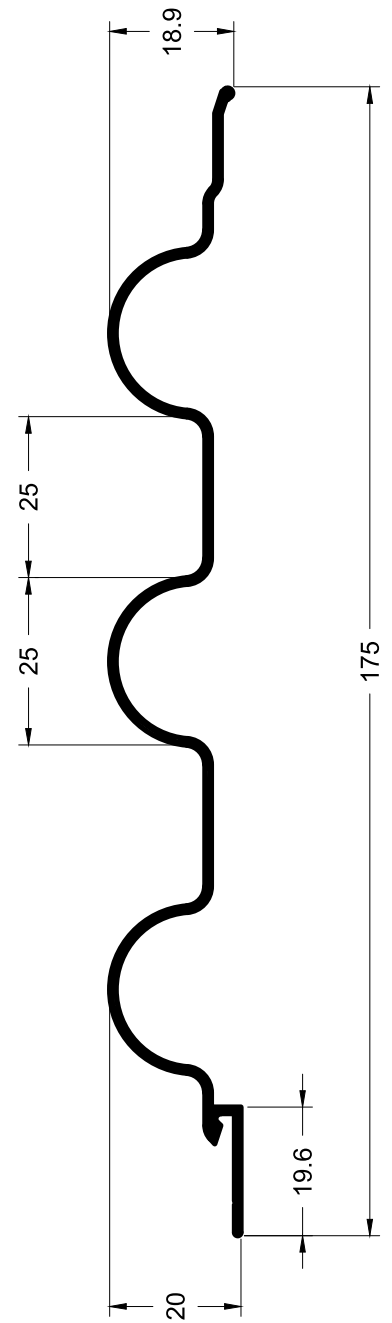

LB 070

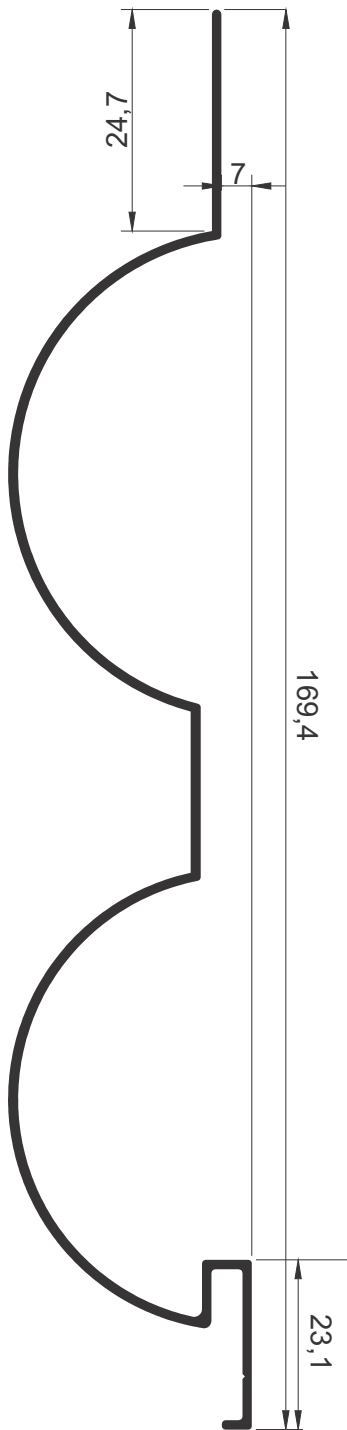

E 0077

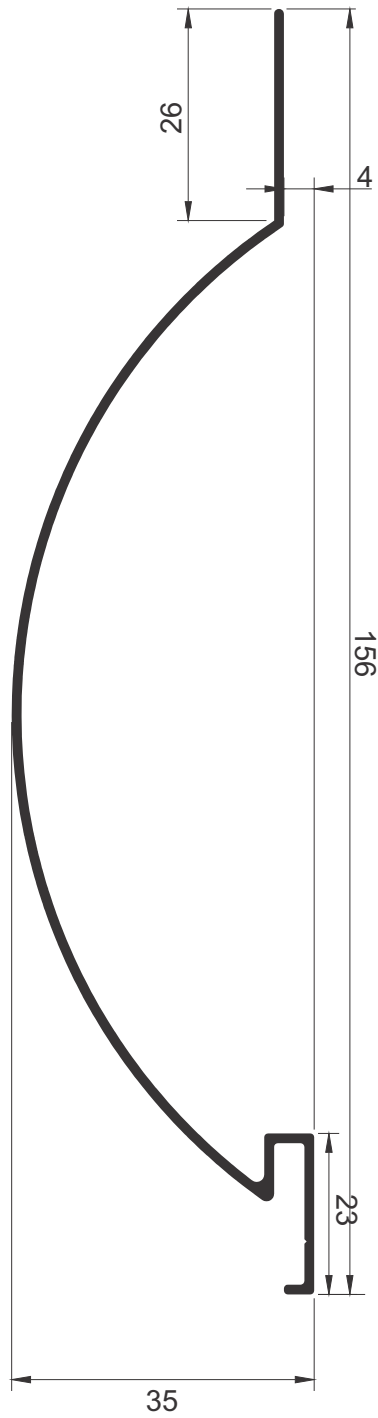

LB 040

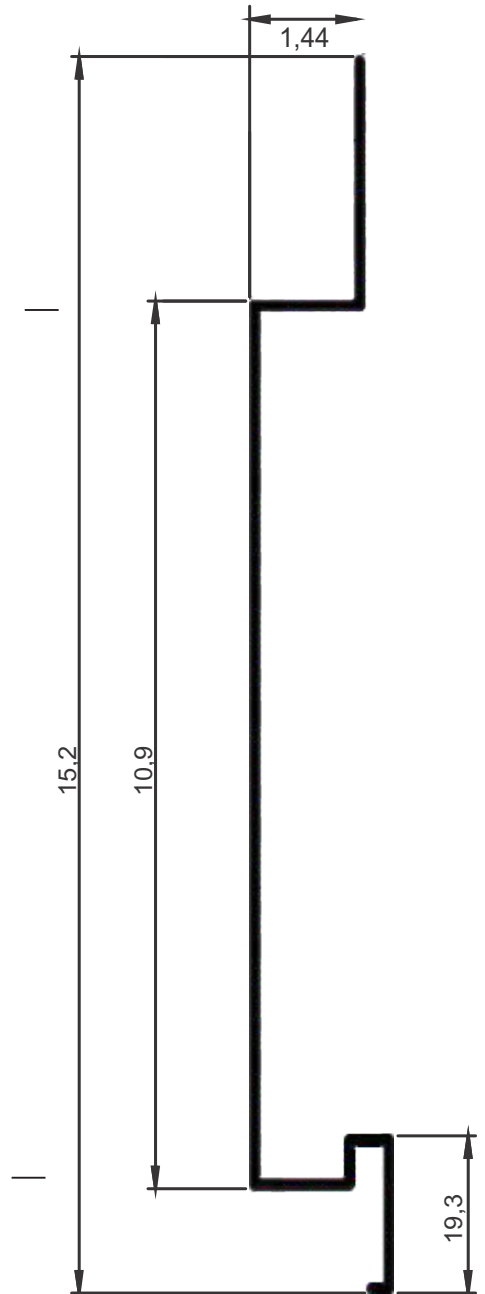

DS 023

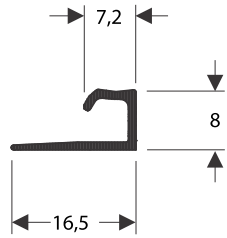

PT 008

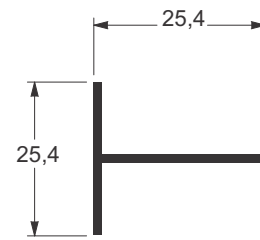

25 517

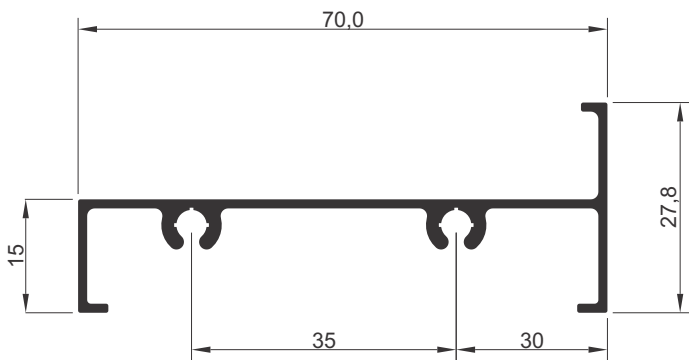

PU 639

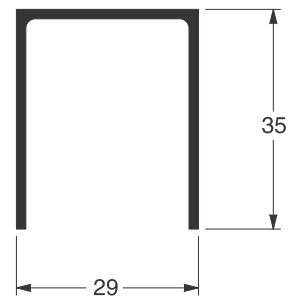

CL 009

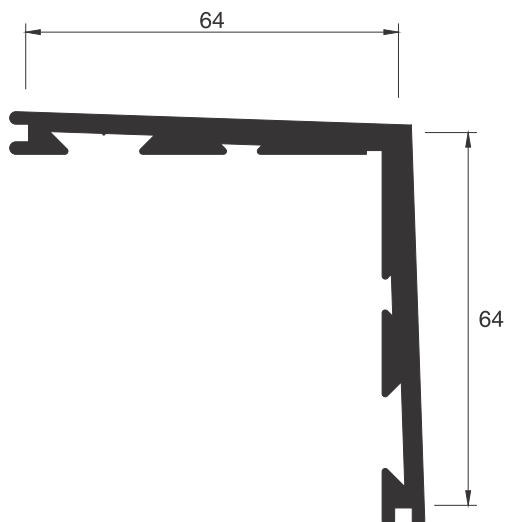

CL 010

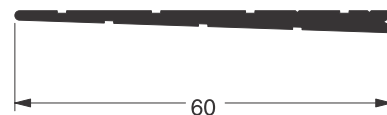

PC 027

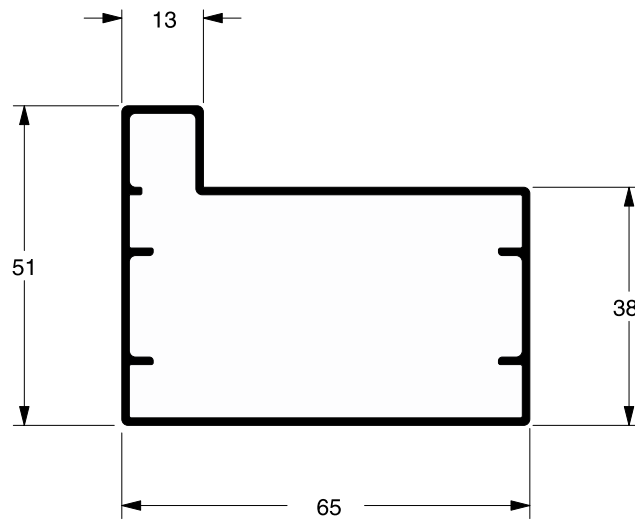

PC 029

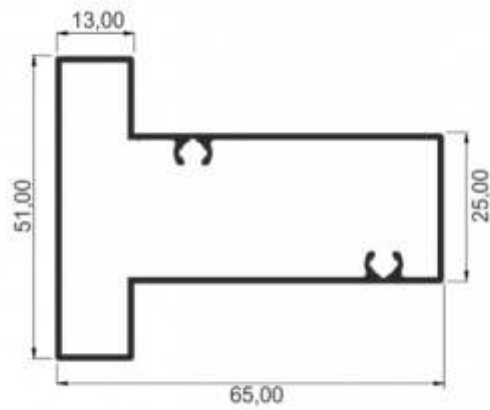

PC 028

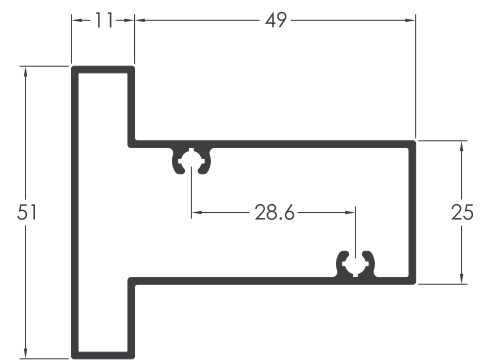

25 518

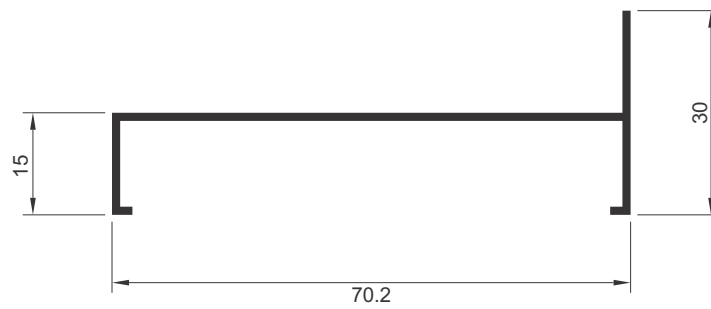

TG 073

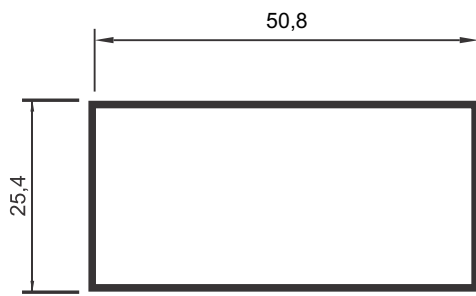

TG 043

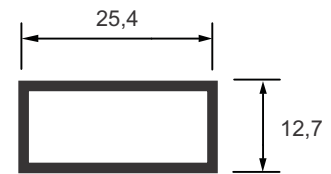

TG 004B

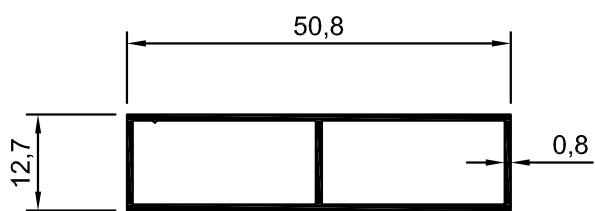

TG 004

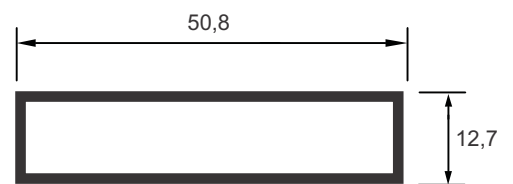

PC 003

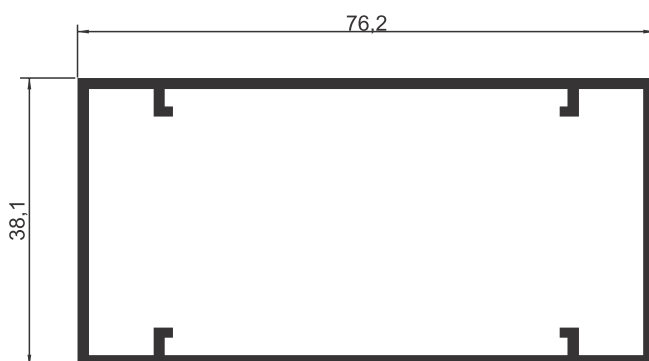

PC 002

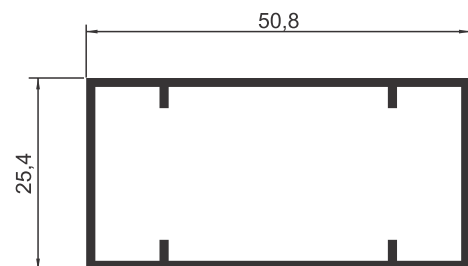

FC 202

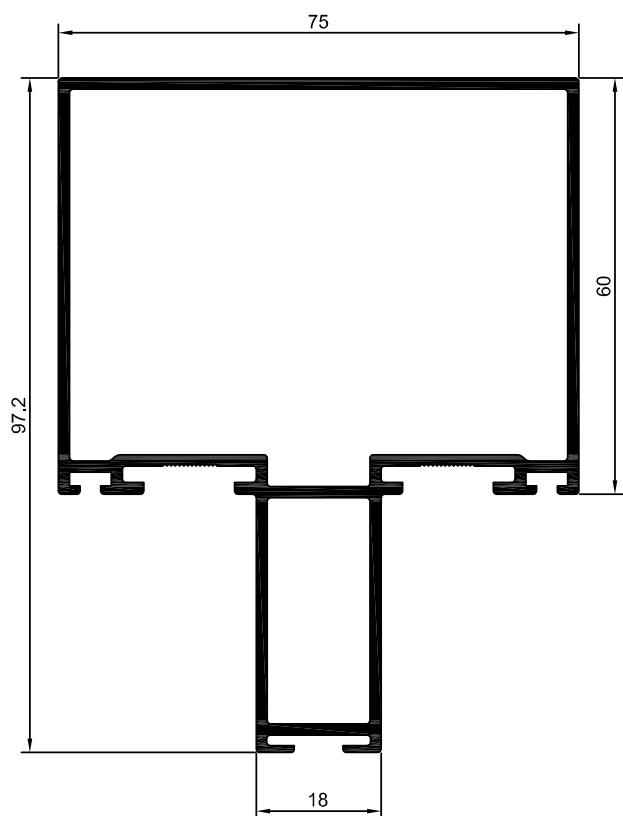

FC 222

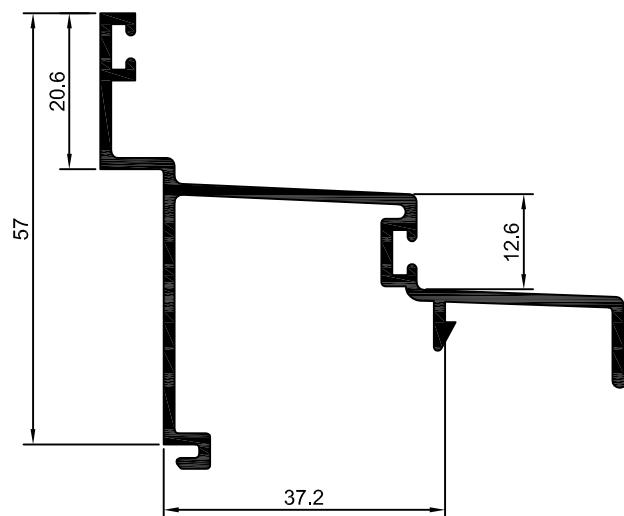

FC 243

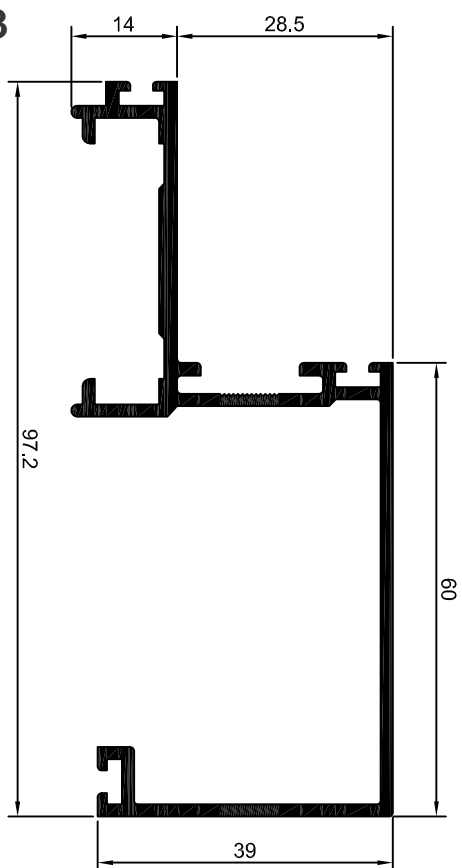

FC 225

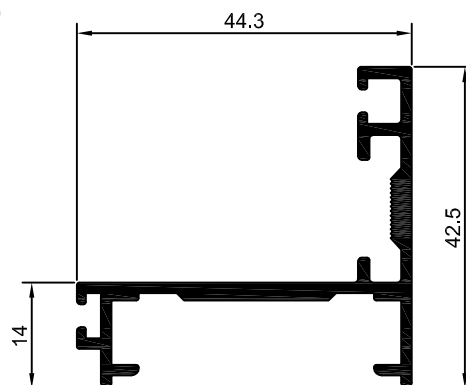

FC 293

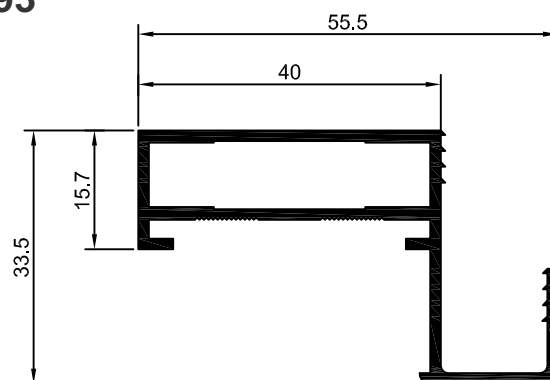

FC 227

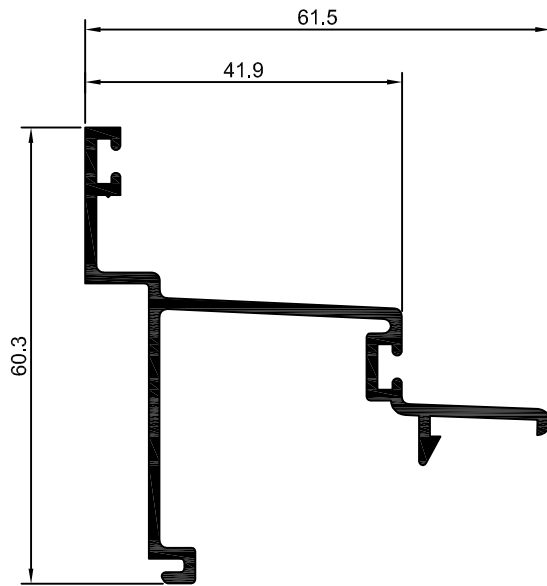

FC 228

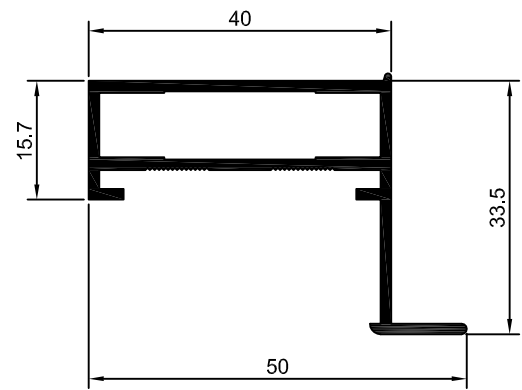

FC 261

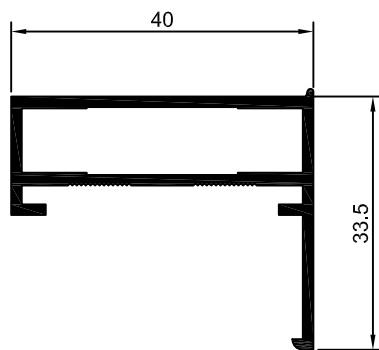

FC 085

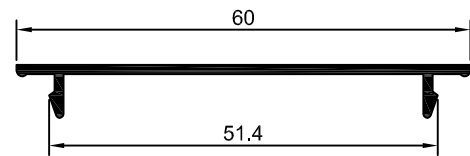

FC 249

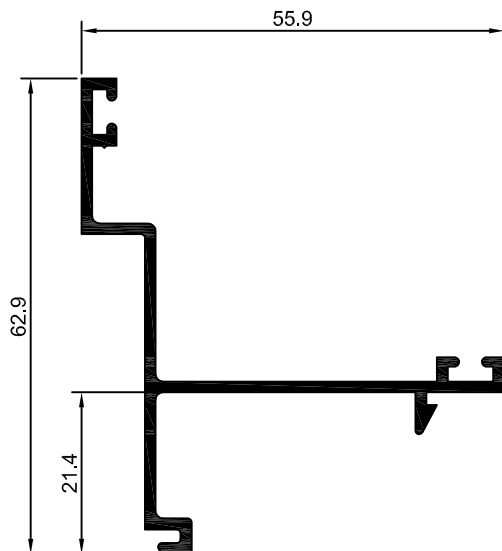

FC 226

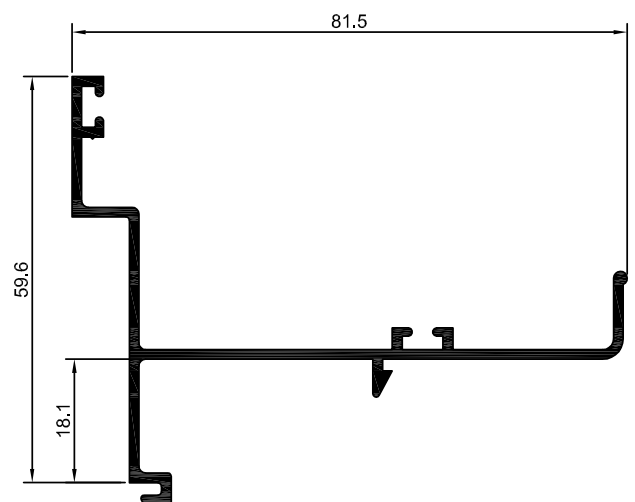

FC 244

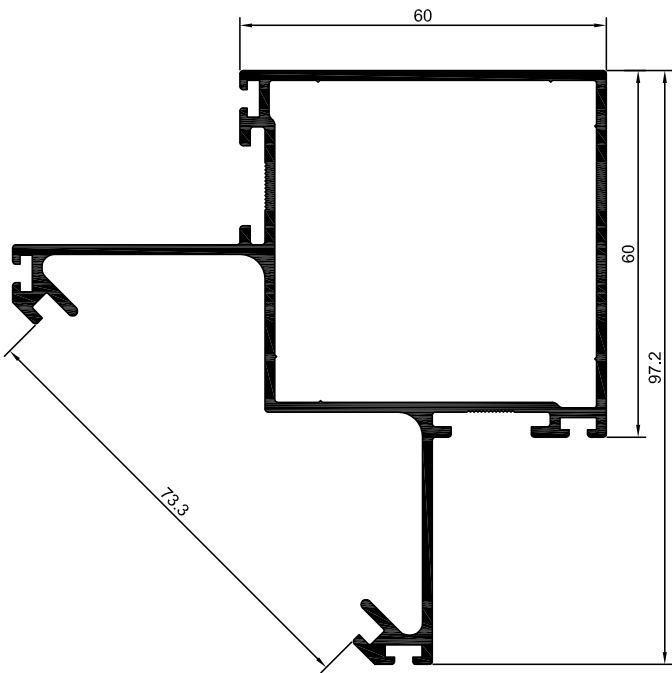

FC 231

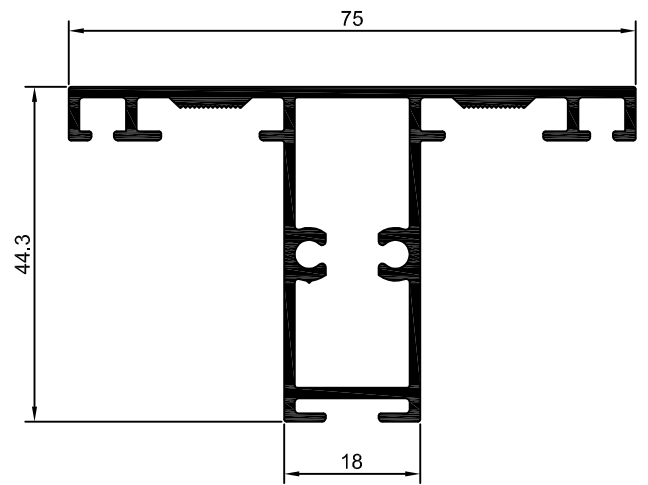

FC 687

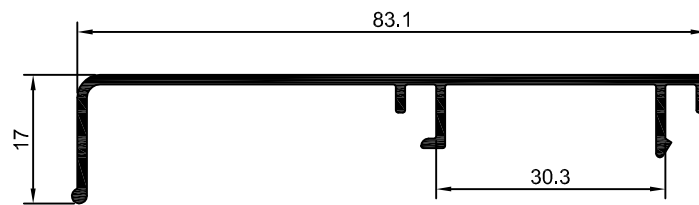

FC 242

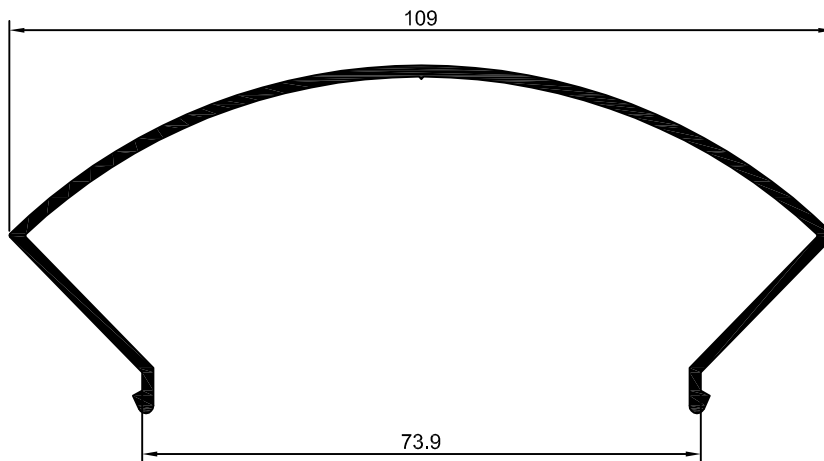

FC 232

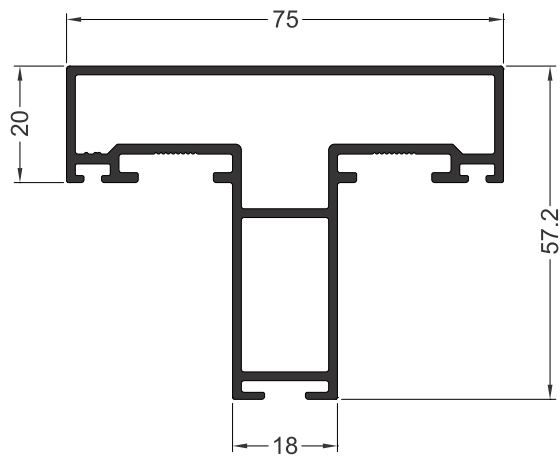

FC 245

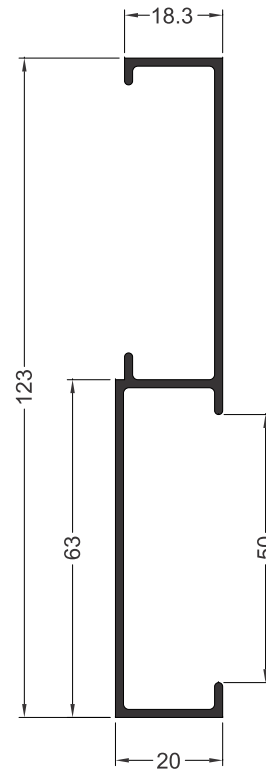

FC 088

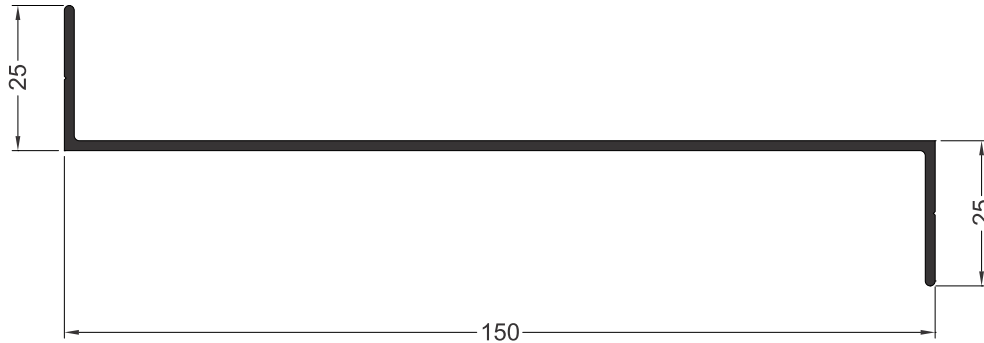

FC 087

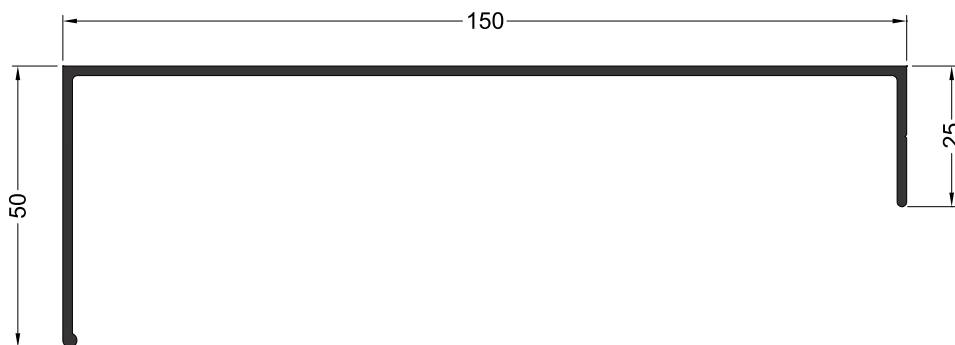

FC 012

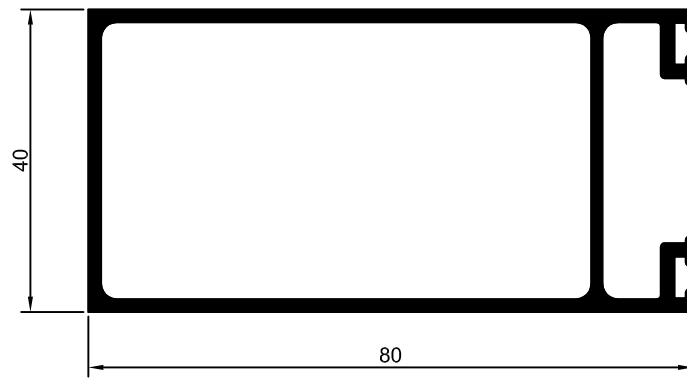

FC 014

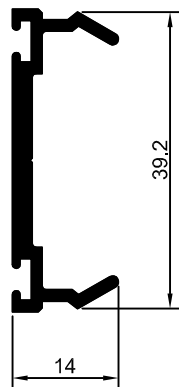

FC 013

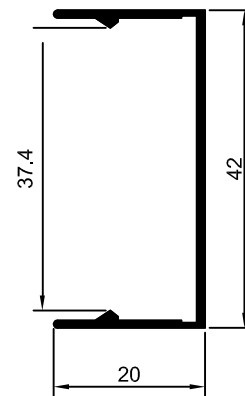

TG 005

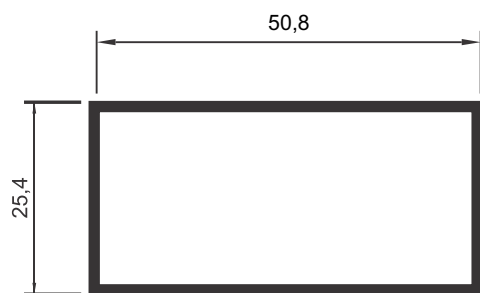

DV 111

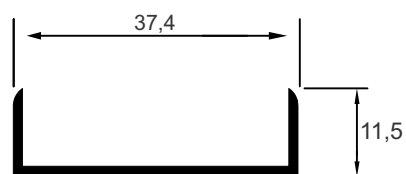

DS 264

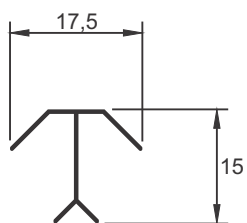

DC 026

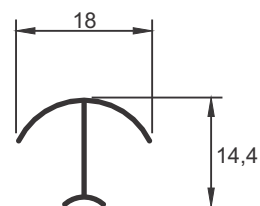

DS 164

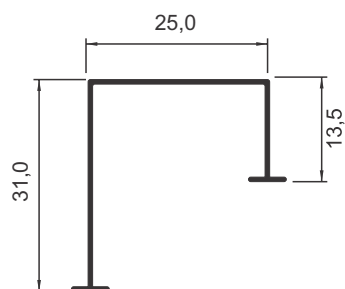

DS 205

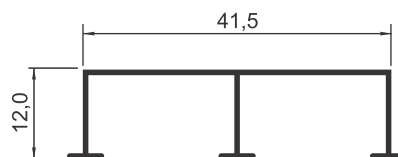

U 1098

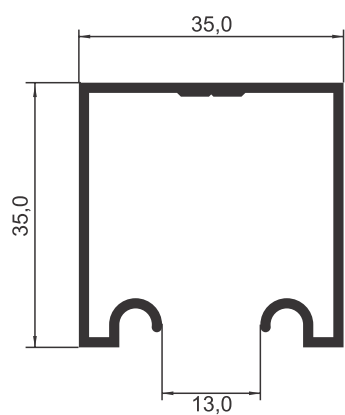

AL 37

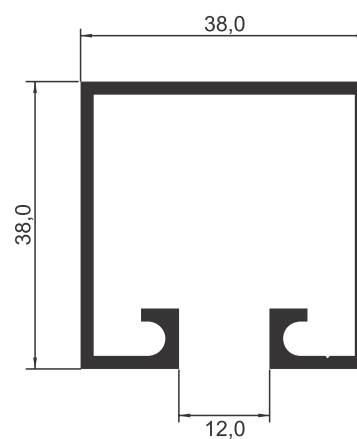

25 549

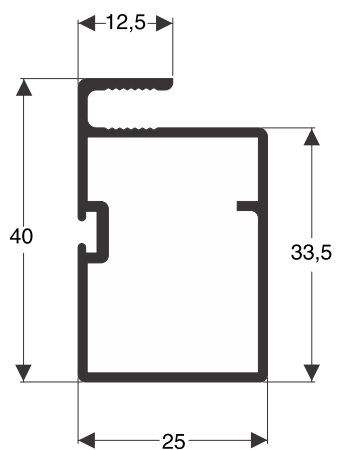

25 551

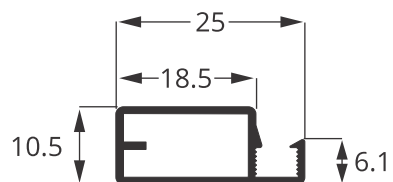

DP 010

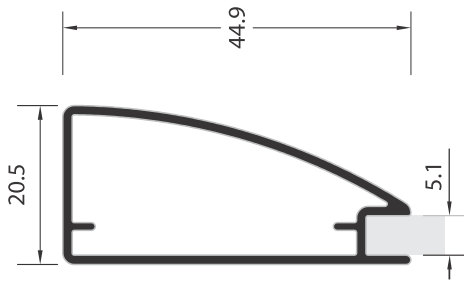

DP 997

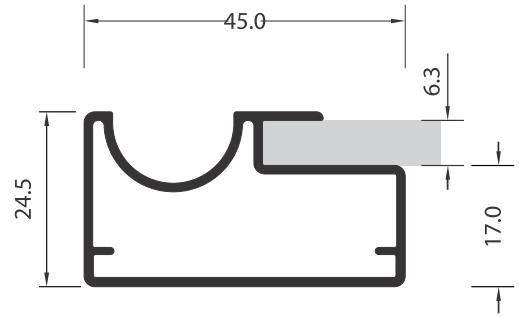

DP 1145

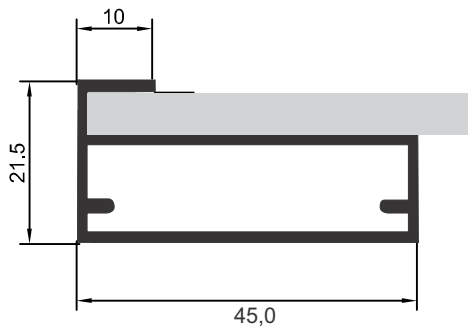

DP 051

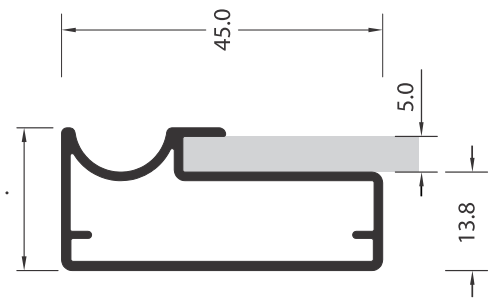

DP 2163

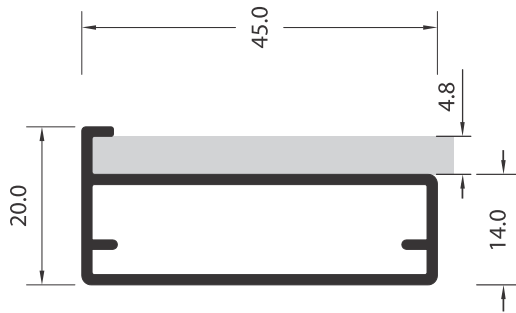

DP 1036

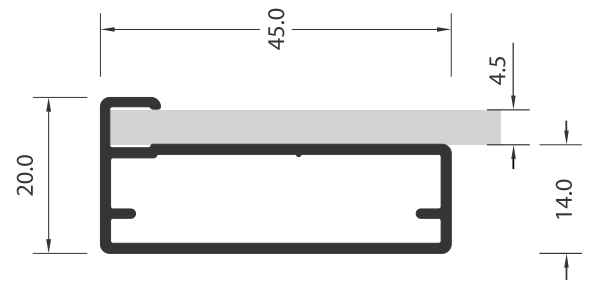

DP 076

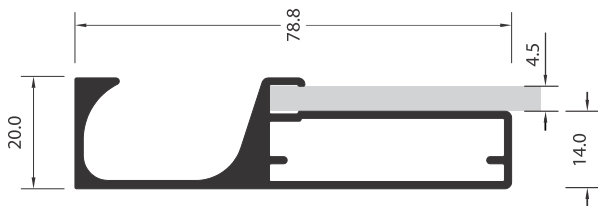

DP 053

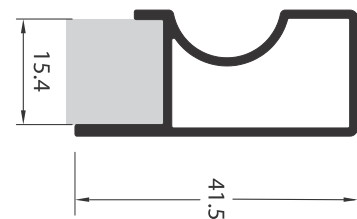

DP 7041

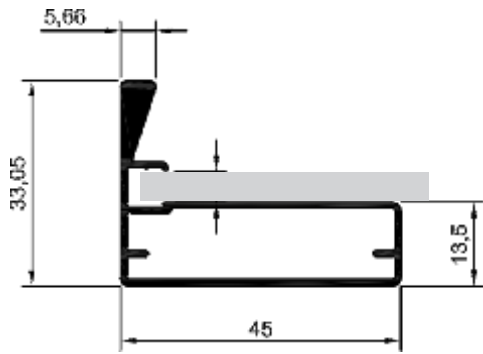

DP 6073

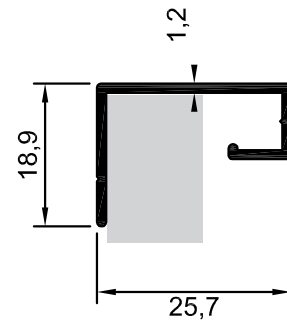

DP 091

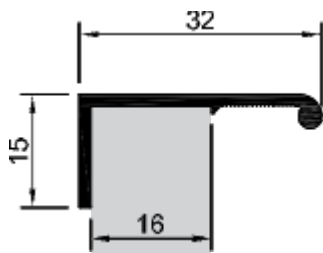

DP 035

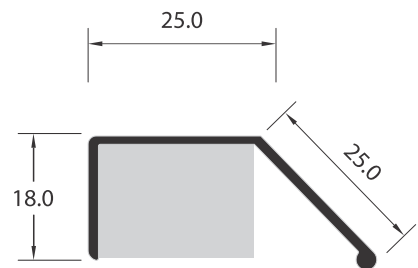

DP 062

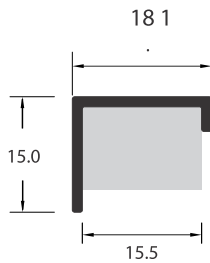

DP 158

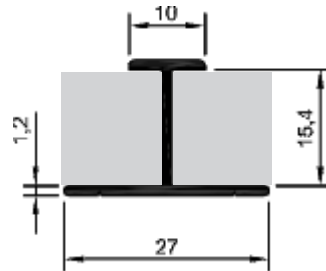

DP 201

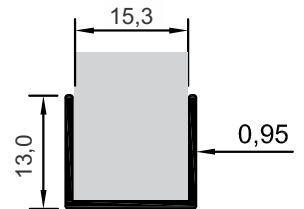

DP 011T

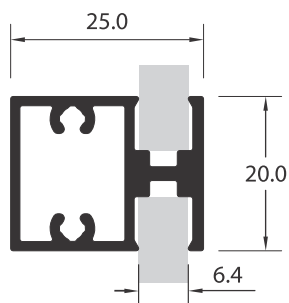

DP 026T

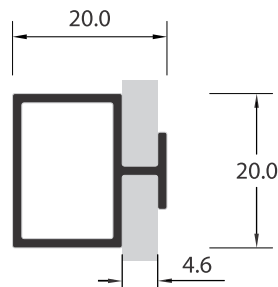

N 0042



DP 015

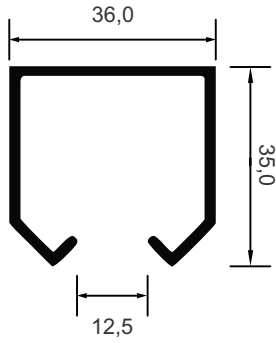

AL 37

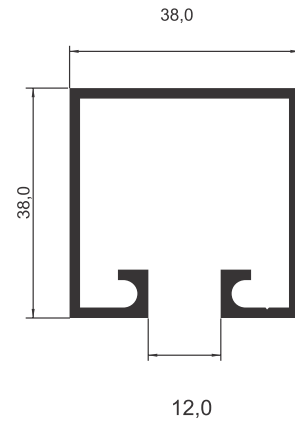

DP 039

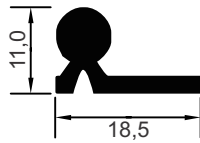

DP 038

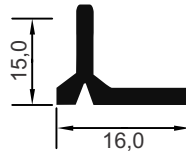

DP 030

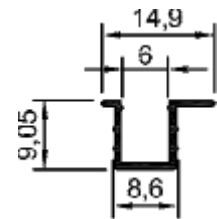

DP 013

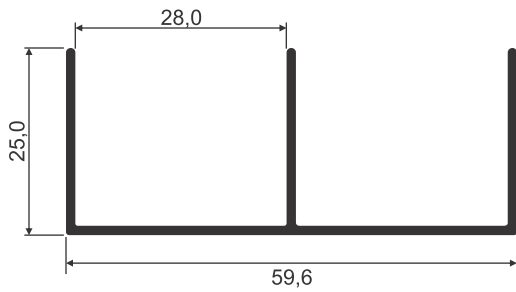

DP 014

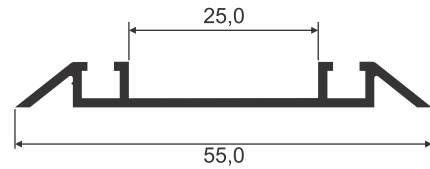

DP 020

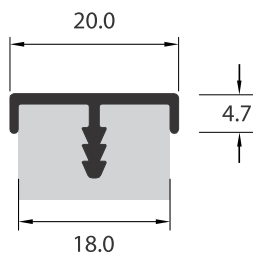

DP 031

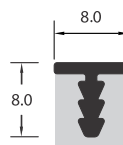

DP 001

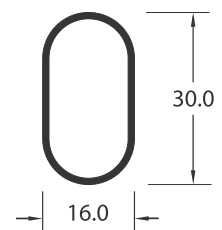

DP 0216

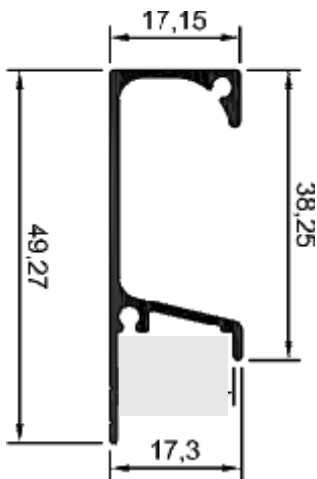

DP 0227

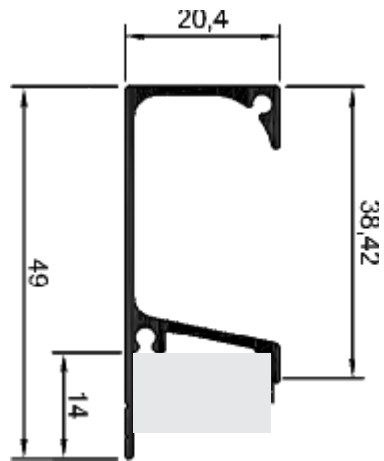

DP 022

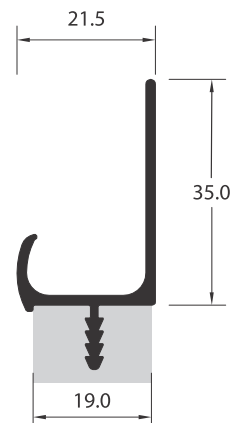

DP 047M

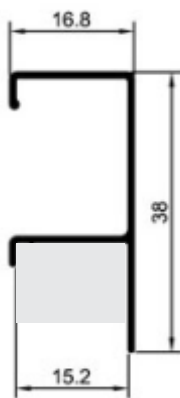

DP 047L

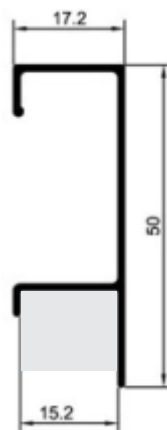

DP 047

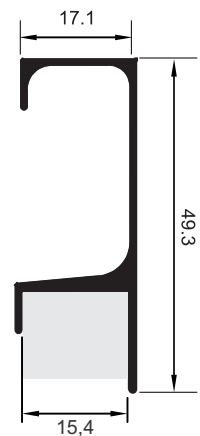

DP 080

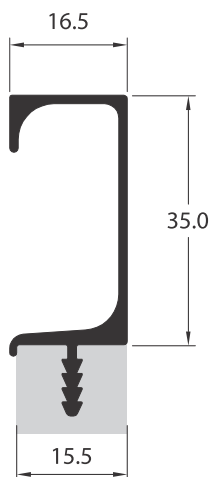

DP 021

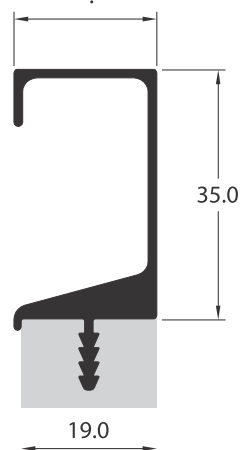

DP 046

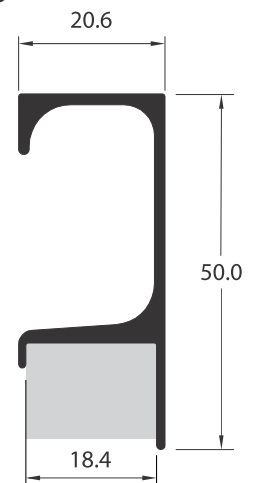

LINHAS

Tabelados
Machos e Conexões
Contra Marcos e Arremates
Linha 25
Módulo Prático
Módulo Max
Venezianas
Unnion
Nova
Gold
Box Pesado
Box Leve
Cortina de Vidro
Vitrine
Kit Pia
Guarda Corpo / Corrimão
Portão
Pele de Vidro
Móveis
Kit Verkatik
Kit Transfer
Box Elegence



DISALPI
PERFIS E COMPONENTES

A **Disalpi** conta com um amplo estoque em perfis de alumínio além da mais completa variedade em acessórios.

Av. Campo Sales, 795
Centro/Norte Teresina-PI
86 3221 2590 | 3223 1544
vendas@disalpialuminio.com.br
www.disalpialuminio.com.br